

**NATIONAL RESEARCH COUNCIL**

ADVISORY COMMITTEE  
ON TECHNICAL RECOMMENDATIONS FOR CONSTRUCTION

**Guide for the Design and Construction of  
Fiber-Reinforced Concrete Structures**



**CNR-DT 204/2006**

**This document is subject to copyright.**

**No part of this publication may be stored in a retrieval system, or  
transmitted in any form or by any means  
– electronic, mechanical, recording, or otherwise –  
without the prior written permission  
of the Italian National Research Council.**

**The reproduction of this document is permitted  
for personal, noncommercial use.**

## CONTENTS

<b>1 FOREWORD.....</b>	<b>5</b>
1.1 PUBLIC HEARING.....	6
1.2 CONTENT AND AIMS OF THE GUIDE.....	7
1.3 REFERENCE STANDARDS.....	7
1.4 SYMBOLS.....	8
1.5 STRUCTURAL PROPERTIES AND BEHAVIOUR OF FIBER-REINFORCED CONCRETE ELEMENTS.....	10
 <b>2 MATERIALS.....</b>	 <b>11</b>
2.1 FIBERS.....	11
2.1.1 Length of the fibers.....	11
2.1.2 Equivalent diameter.....	11
2.1.3 Aspect ratio.....	11
2.1.4 Tensile strength of fiber.....	12
2.1.5 Modulus of elasticity.....	12
2.2 STEEL FIBERS.....	12
2.3 POLYMERIC AND CARBON FIBERS.....	13
2.4 MATRIX.....	15
2.5 FIBER REINFORCED CONCRETE.....	15
2.5.1 Fresh State Properties.....	15
2.5.1.1 Rheological properties.....	15
2.5.1.2 Homogeneity of the mix.....	15
2.5.1.3 Plastic shrinkage.....	16
2.5.2 Mechanical properties hardening state.....	16
2.5.2.1 Compressive behaviour.....	16
2.5.2.2 Tensile behaviour.....	16
2.5.2.3 Stress-strain constitutive law.....	19
2.5.2.4 Modulus of elasticity.....	20
2.5.3 Physical properties at hardened state.....	21
2.5.3.1 Drying shrinkage.....	21
2.5.3.2 Freezing and thawing resistance.....	21
2.5.3.3 Penetration of aggressive ions.....	21
2.5.3.4 Carbonation.....	21
2.5.3.5 Fiber corrosion.....	21
2.5.3.6 Fire resistance.....	21
2.6 STEEL.....	21
 <b>3 DESIGN BASIC CONCEPTS AND SPECIAL PROBLEMS.....</b>	 <b>22</b>
3.1 GENERAL.....	22
3.2 BASIC REQUIREMENTS.....	22
3.3 DESIGN SERVICE LIFE.....	23
3.4 GENERAL RULES FOR DESIGN.....	23
3.4.1 General.....	23
3.4.2 Design values.....	23
3.4.3 Material properties.....	23
3.4.4 Design resistance.....	24
3.5 CHARACTERISTIC VALUES OF MATERIAL STRENGTH.....	24
3.6 PARTIAL SAFETY FACTORS.....	24
3.6.1 Partial Safety Factors for materials.....	24

3.6.2	Partial factors $\gamma_{Rd}$ for the resistance models .....	25
3.7	DURABILITY REQUIREMENTS.....	25
<b>4</b>	<b>ULTIMATE LIMIT STATES (ULS) VERIFICATION.....</b>	<b>28</b>
4.1	ULS FOR MONO-DIMENSIONAL ELEMENTS.....	28
4.1.1	General.....	28
4.1.2	Bending with axial force.....	28
4.1.3	Shear .....	29
4.1.3.1	General .....	29
4.1.3.2	Members without design shear and conventional longitudinal reinforcement .....	29
4.1.3.3	Members without design shear reinforcement, with conventional longitudinal reinforcement .....	29
4.1.3.4	Members with shear and longitudinal conventional reinforcement.....	30
4.1.3.5	Minimum shear reinforcement.....	31
4.1.4	Torsion.....	32
4.1.4.1	Members without torsional longitudinal and transverse conventional reinforcement .....	32
4.1.4.2	Members with torsional longitudinal and transverse conventional reinforcement .....	32
4.2	PLATE ELEMENTS.....	32
4.2.1	Plate elements without conventional reinforcement.....	32
4.2.2	Plate elements with conventional reinforcement.....	33
4.3	SLAB ELEMENTS.....	33
4.3.1	Slab elements without conventional reinforcement.....	33
4.3.2	Slab element with conventional reinforcement .....	34
<b>5</b>	<b>SERVICEABILITY LIMIT STATES (SLS) .....</b>	<b>35</b>
5.1	STRESS VERIFICATION .....	35
5.2	CRACK WIDTH.....	35
5.3	MINIMUM REINFORCEMENT FOR CRACK CONTROL.....	35
<b>6</b>	<b>CONSTRUCTION.....</b>	<b>37</b>
6.1	MIX COMPOSITION .....	37
6.2	DETAILING OF REINFORCEMENT.....	37
6.3	MINIMUM DIMENSIONS .....	37
6.3.1	Minimum thickness of structural members .....	37
6.3.2	Minimum value of spacing of bars and concrete cover.....	37
6.4	CASTING.....	38
<b>7</b>	<b>FIRE RESISTANCE.....</b>	<b>39</b>
<b>8</b>	<b>PRELIMINARY TESTS AND PRODUCTION CONTROL.....</b>	<b>41</b>
8.1	PRELIMINARY TESTS .....	41
8.2	PRODUCTION CONTROL FOR TYPE A APPLICATIONS .....	41
8.3	PRODUCTION CONTROL FOR TYPE B APPLICATIONS.....	41
<b>9</b>	<b>APPENDIX A (ON THE TENSILE STRENGTH: CONSTITUTIVE PARAMETER IDENTIFICATION) .....</b>	<b>42</b>
9.1	SOFTENING BEHAVIOUR MATERIALS SUBJECTED TO TENSION IDENTIFIED THROUGH BENDING TESTS.....	42
9.1.1	Linear elastic model.....	42
9.1.2	Rigid-plastic model.....	44

9.1.3	Notched specimen (according to UNI 11188).....	44
9.1.4	Unnotched structural specimen (according to standard UNI 11188) .....	44
9.2	<b>MATERIALS IDENTIFIED WITH TENSION TESTS</b> .....	45
9.2.1	Notched specimen (according to UNI 11039).....	45
9.2.2	Unnotched specimen.....	46
<b>10</b>	<b>APPENDIX B (QUALITY CONTROL CRITERIA) .....</b>	<b>47</b>
10.1	BENDING TESTS ON SOFTENING BEHAVIOUR MATERIALS.....	47
<b>11</b>	<b>APPENDIX C (ON THE MECHANICAL CHARACTERIZATION TESTS FOR HARDENING BEHAVIOUR MATERIALS).....</b>	<b>49</b>
11.1	TENSION TEST .....	49
11.1.1	Specimen preparation .....	49
11.1.2	Test equipment.....	49
11.1.3	Load application .....	50
11.2	BENDING TEST.....	50
<b>12</b>	<b>APPENDIX D (MATERIAL STRENGTH: CALCULATION OF CHARACTERISTIC VALUES FOR STRUCTURAL DESIGN).....</b>	<b>51</b>
<b>13</b>	<b>APPENDIX E (EXPERIMENTAL DETERMINATION OF DAMAGE COEFFICIENTS DUE TO FIRE) .....</b>	<b>54</b>



# 1 FOREWORD

This document contributes to the series published over the last few years by the Italian CNR (National Research Council) relating to the structural use of composite materials, with the first volume being the Instructions n. 200 in 2004. The documents published so far have dealt with the following: plating of reinforced and prestressed concrete as well as masonry structures through the use of long fibers reinforced composite materials (FRP) (CNR-DT 200/2004), plating of timber structures (CNR-DT 201/2005) as well as metallic ones (CNR-DT 202/2005) and finally, the use of FRP bars as reinforcement of concrete structures (CNR-DT 203/2006).

The subject of this document is the structural use of a completely different composite material: Fiber Reinforced Concrete (FRC). It does not have a polymeric matrix like a Fiber Reinforced Polymer (FRP) but a cementitious matrix to which short fibers are added. They can be made of steel, polymeric materials as well as inorganic materials such as carbon, glass and natural materials. Furthermore, an ordinary steel reinforcement as well as reinforcing prestressed bars can also be present. The adding of fibers to concrete gives a significant residual strength after cracking. This property depends on many factors, including the aspect ratio (corresponding to the length/equivalent diameter of the fibers), the volumetric percentage of the fibers as well as their physical and mechanical properties.

FRC structures have become gradually more widespread worldwide over the last few years. This has consequently led to the drawing up of technical guidelines becoming necessary.

The most significant international documents dealing with FRC are the following:

- RILEM, 2000, "Test and design methods for steel fiber reinforced concrete: beam test", RILEM TC 162-TDF Recommendations, *Materials and Structures*, 33: 3-5;
- RILEM, 2000, "Test and design methods for steel fiber reinforced concrete.  $\sigma$ - $\varepsilon$  Design Method", RILEM TC 162-TDF Recommendations, *Materials and Structures*, 33: 75-81;
- RILEM, 2001, "Test and design methods for steel fiber reinforced concrete: uniaxial tension test for steel fiber reinforced concrete", RILEM TC 162-TDF Recommendations, *Materials and Structures*, 34: 3-6;
- RILEM, 2002, "Test and design methods for steel fiber reinforced concrete. Design of steel fiber reinforced concrete using the  $\sigma$ -w method: principles and applications", RILEM TC 162-TDF Recommendations, *Materials and Structures*, 35: 262-278;
- ACI Committee 544, 1999, "Measurement of properties of Fiber Reinforced Concrete", ACI 544.2R-98, *American Concrete Institute*, ACI Farmington Hills, MI;
- ACI Committee 544, 1996, "Design considerations for steel Fiber Reinforced Concrete", ACI 544.4R-88, *American Concrete Institute*, ACI Farmington Hills, MI;
- ACI Committee 544, 1996, "State of the art Report on Fiber Reinforced Concrete", ACI 544.1R-96, *American Concrete Institute*, ACI Farmington Hills, MI;
- JCI, 1984, "Method of tests for flexural strength and flexural toughness of fiber reinforced concrete", JCI Standard SF-4, JCI Standards for test methods of fiber reinforced concrete, *Japan Concrete Institute*.

Some of the most interesting and relevant examples of FRC applications include:

- load-bearing front panels;
- floor slabs;
- convention and segmental tunnel linings;
- beams;
- structural joints (in order to reduce the high percentage of conventional reinforcement);

- thin walled roof elements without conventional diffused reinforcement;
- structures designed to resist either impact or fatigue loadings, such as high pressured vessels and tubes, railway tracks, poles etc.;
- sheltering structures

The main use of fiber-reinforced concrete is in the construction of statically redundant structures, where the residual tensile strength can improve the load bearing capacity of the structure as well as its ductility.

The enhanced toughness due to the introduction of short fibers into the cement mix can also lead to a growing use of high performance concretes, even for those applications that are particularly critical due to its brittleness (without fibers) that often characterises such materials in the absence of fibers.

The aim of these Guidelines is to draw up a document for the design, construction and control of FRC structures, in accordance with the Building Codes. The proposed approach is based on that of the limit state design, with the lay out being that of “principles” and “requirements” as set out in the Eurocodes. In this document, the principles are denoted by the symbol “P”.

These Guidelines do not intend to be binding Codes but rather represent an aid for all technicians to filter through the large amount of literature currently available.

This document also has an Appendix that deals with several theoretical topics in greater detail, briefly mentioned in the Guidelines, due to their innovative nature, with the aim of making them more well known.

This Technical Document has been prepared by a Task Group whose members are:

ASCIONE Prof. Luigi	- University of Salerno
BERARDI Dr. Valentino Paolo	- University of Salerno
DI PRISCO Prof. Marco	- Polytechnic of Milano
FAILLA Dr. Claudio	- Magnetti Building S.p.a. - Carvico (BG)
GRIMALDI Prof. Antonio	- University “Tor Vergata” - Roma
MEDA Prof. Alberto	- University of Bergamo
RINALDI Dr. Zila	- University “Tor Vergata” - Roma
PLIZZARI Prof. Giovanni	- University of Brescia
SAVOIA Prof. Marco	- University of Bologna

Coordinator:

GRIMALDI Prof. Antonio.

General Coordinator:

ASCIONE Prof. Luigi.

Technical Secretariat:

FEO Prof. Luciano, ROSATI Prof. Luciano.

## **1.1 PUBLIC HEARING**

After its publication, this document CNR-DT 204/2006 was subject to a public hearing. Following the public hearing, some modifications and/or integrations have been made to the document including corrections of typos, additions of subjects that had not been dealt with in the original version, and elimination of others deemed not to be relevant.

This Technical Document has been approved as a final version on 28/11/2007, including the modifications derived from the public hearing, by the “Advisory Committee on Technical Recommendation for Construction”, whose members are:



ANGOTTI Prof. Franco	- University of Firenze
ASCIONE Prof. Luigi	- University of Salerno
BARATTA Prof. Alessandro	- University "Federico II"- Napoli
COSENZA Prof. Edoardo	- University "Federico II"- Napoli
GIANGRECO Prof. Elio	- University "Federico II"- Napoli
JAPPELLI Prof. Ruggiero	- University "Tor Vergata" - Roma
MACERI Prof. Franco, Chairman	- University "Tor Vergata" - Roma
MAZZOLANI Prof. Federico Massimo	- University "Federico II"- Napoli
PINTO Prof. Paolo Emilio	- University "La Sapienza" - Roma
POZZATI Prof. Piero	- University of Bologna
SOLARI Prof. Giovanni	- University of Genova
URBANO Prof. Carlo	- Polytechnic of Milano
VINCI Dr. Roberto	- Italian National Research Council
ZANON Prof. Paolo	- University of Trento

## 1.2 CONTENT AND AIMS OF THE GUIDE

- (1) The object of the document is fiber-reinforced concrete structures (FRC).
- (2) P Fiber-reinforced concrete is a composite material characterised by a cement matrix and discrete fibers (discontinuous). The matrix is made of either concrete or mortar, normal or high performance. The fibers can be either of steel, polymeric, carbon, glass or natural materials.
- (3) P A minimum fiber content of fibers must be guaranteed for the structural uses as specified in Chapter 2.
- (4) Metallic, polymeric and carbon fibers are dealt with exclusively in this present document. However the design rules can also be adopted for FRC made with other types of fibers, e.g. glass/natural, as long as their structural behaviour is similar to the analogous concrete elements considered in this document.
- (5) The property of the composite depends on the characteristics of the constituent materials as well as their dosage. Other factors include the geometry and the mechanical properties of the fibers, the bond between the fiber and the concrete matrix, and the mechanical properties of the matrix. The fibers can contribute to mitigate cracking phenomena and/or significantly increase the energy absorbed in the cracking process.
- (6) Once cast, fiber-reinforced concrete acquires properties that also depend on factors connected to the construction technology as well as to the dimensions of the structure size. These include fiber dispersion in the mix, the shape and dimensions of the structure, the possible anisotropy due to fiber orientation related to casting direction.

## 1.3 REFERENCE STANDARDS

Reference is made to the following:

CEN EN 1992-1-1, 2004: Eurocode 2 – Design of concrete structures-Part 1-1:general rules and rules for buildings.

CEN EN 14721 (2005): Precast concrete products – test method for metallic fiber concrete – measuring the fiber concrete in fresh and hardened concrete.

CEN EN 14651 (2005): Test method for metallic fiber concrete – Measuring the flexural tensile strength (limit of proportionality (*LOP*), residual).

UNI 11188, 2004: Design, Production and Control of Steel Fiber Reinforced Structural Elements.

UNI 11039, 2003: Concrete reinforced with steel fibers; (1a) Part I: Definitions, classification and designation; (1b) Part II: Test method to determine first cracking strength and ductility indexes.  
 UNI EN 12390, 2002: Tests on hardened concrete.  
 UNI EN 206-1, 2001: Concrete: specification, performance, production and conformity.  
 UNI 9502, 2001: Analytical fire resistance assessment of reinforced concrete and prestressed concrete structural elements.

## 1.4 SYMBOLS

The meaning of the main symbols used in the document is hereafter reported.

### General notations

$(.)_c$	quantity (.) referred to concrete
$(.)_d$	design value of quantity (.)
$(.)_{exp}$	experimental value of quantity (.)
$(.)_F$	quantity (.) referred to fiber-reinforced concrete
$(.)_k$	characteristic value of quantity (.)
$(.)_m$	medium value of quantity (.)
$(.)_R$	quantity (.) as resistance
$(.)_s$	quantity (.) referred to steel
$(.)_S$	quantity (.) as demand
$(.)_u$	ultimate value of quantity (.)

### Uppercase Roman letters

$A_c$	area of the concrete cross-section, net of steel reinforcement
$A_f$	area of a single fiber
$A_{s1}$	area of the longitudinal steel reinforcement
$A_{sw}$	area of the transverse reinforcement
$K_{fc}$	fire degradation of the strength in compression
$K_{Ft}$	fire degradation of the strength in uniaxial tension
$P$	load
$T$	temperature
$V_f$	volume fraction of fibers
$V_{Rd}$	design value of shear bearing capacity of the structural element
$V_{Rd,F}$	fiber contribution to the design value of shear bearing capacity
$V_{Rd,s}$	stirrup contribution to the design value of shear bearing capacity

### Lowercase Roman letters

$b_f$	width of a rectangular cross-section fiber
$d$	effective depth of the cross-section
$d_a$	maximum aggregates size
$d_f$	fiber diameter (equivalent)
$f_F$	FRC strength in compression (prismatic and cylindrical specimens)
$f_{Ft}$	FRC tensile strength
$f_{Ftf}$	FRC tensile strength in bending
$f_{Fts}$	FRC service tensile residual strength
$f_{Ftu}$	FRC ultimate tensile residual strength
$f_c$	matrix strength in compression (for prismatic and cylindrical specimens)
$f_{ct}$	matrix tensile strength
$f_{ctf}$	matrix tensile strength in bending
$f_y$	yield strength of the longitudinal steel reinforcement

$f_{yd}$	design yield strength of longitudinal steel reinforcement
$f_{yw}$	design yield strength of stirrups
$h$	cross - section depth
$h_f$	fiber thickness for rectangular sections
$i$	spacing of bars
$l_{cs}$	characteristic length of the structural element
$l_f$	fiber length
$l_d$	fiber development length
$m$	fiber mass
$p$	spacing of stirrups
$s_{rm}$	mean crack distance
$t$	structural element thickness
$w$	CTOD – Crack Tip Opening Displacement
$x$	distance of the neutral axis from the extreme edge in compression
$y$	distance of the neutral axis from the extreme edge in tension

**Lowercase Greek letters**

$\varepsilon_F$	tensile strain in FRC
$\varepsilon_c$	compressive strain in FRC
$\varepsilon_s$	tensile strain in steel rebars
$\phi$	diameter of rebars
$\gamma_c$	partial safety factor for FRC in compression
$\gamma_F$	partial safety factor for FRC in tension
$\gamma_{Rd}$	partial safety factor for mechanical model
$\gamma_s$	partial safety factor for steel rebars
$\rho_f$	fiber mass density

## 1.5 STRUCTURAL PROPERTIES AND BEHAVIOUR OF FIBER-REINFORCED CONCRETE ELEMENTS

(1)P The mechanical properties of a cementitious matrix are modified when fibers are added. The post-cracking tensile behaviour is improved since contrast crack propagation.

Once the matrix has cracked, fibers remarkably enhance the post-cracking resistance that can not be found in a matrix without fibers.

The softening behaviour, typical of a uniaxial test, can be significantly modified by adding fibers.

For small fiber volume fractions (approx.  $< 2\%$ ), the FRC load-displacement constitutive relationship still presents a decreasing branch (softening behaviour), but it is characterised by both a residual strength as well as a significant toughness (Figure 1a). For higher volume fractions of fibers (approx.  $> 2\%$ ), the post-cracking behaviour could become hardening, due to the occurrence of multiple cracking (Figure 1b).

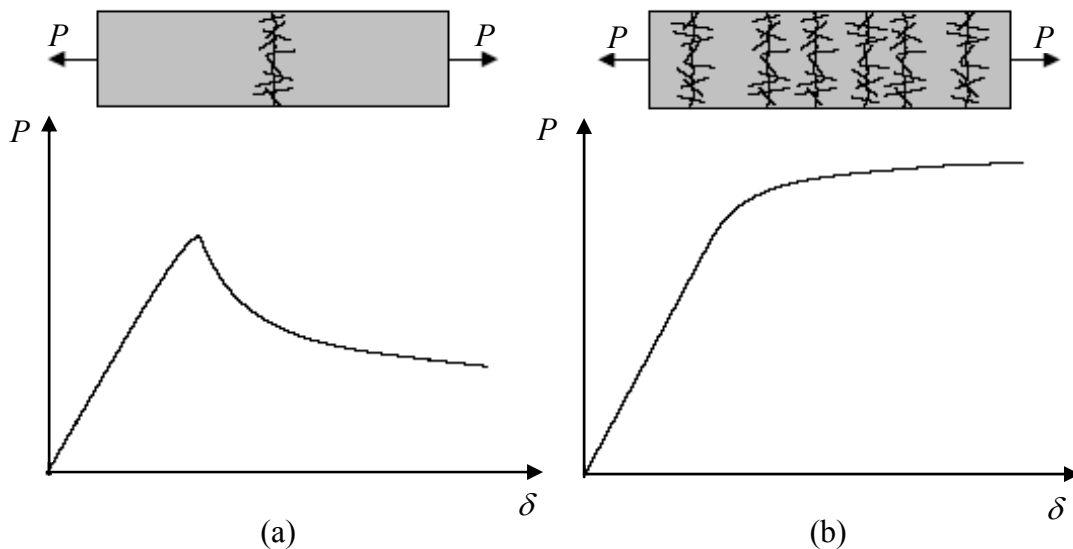

**Figure 1-1** – Load ( $P$ ) – displacement ( $\delta$ ) from a uniaxial tensile test on fiber-reinforced concrete characterised by a low percentage of fibers (a) and a high percentage of fibers (b).

(2)P FRC properties, used for a specific structural purpose, must be suitably defined and verified. There are two different ways of characterising FRC: one is based on nominal properties, whereas the other is based on structural properties.

(3)P Nominal properties of FRC should be established by carrying out normalised tests under controlled conditions by means of standard laboratory procedures.

(4)P Structural properties of FRC must be referred to the material being used in practise and should be evaluated through tests on the same scale of the structure. These tests should be carried out in the same environment as the real structure and the direction of the applied loads in relation to that of casting should be the same as in the real structure.

## 2 MATERIALS

### 2.1 FIBERS

(1)P The fibers are characterised by both material properties as well as geometrical parameters including the length, the equivalent diameter, the aspect ratio and the shape (straight, hooked fibers, etc).

#### 2.1.1 Length of the fibers

(1)P The fiber length  $l_f$ , is the distance between the outer ends of the fiber.  
The developed length of the fiber  $l_d$ , is the length of the axis line of the fiber.  
The length of the fiber should be measured according to specific reference codes.

#### 2.1.2 Equivalent diameter

(1)P The equivalent diameter,  $d_f$ , is the diameter of a circle with an area equal to the mean cross-sectional area of the fiber.

(2) For circular cross sections with a diameter greater than 0.3 mm, the equivalent diameter of the fiber shall be measured with a micrometer, in two directions, approximately at right angles, with an accuracy in accordance to specific reference codes. The equivalent diameter is given by the mean value of the two diameters.

(3) For fibers with a diameter less than 0.3 mm, the diameter shall be measured with optical devices, with an accuracy in accordance to specific reference codes.

(4) For elliptical sections, the equivalent diameter shall be evaluated starting from the measuring of the two axes, using a micrometer with an accuracy in accordance to specific reference codes. The equivalent diameter is given by the mean length of the two axes.

(5) For rectangular sections, the width,  $b_f$ , and the thickness,  $h_f$ , shall be measured in accordance to specific reference codes. The equivalent diameter is given by:

$$d_f = \sqrt{\frac{4 \cdot b_f \cdot h_f}{\pi}}. \quad (1.1)$$

(6) Alternatively, and in particular for fibers with irregular sections, the equivalent diameter can be evaluated with the following formula:

$$d_f = \sqrt{\frac{4 \cdot m}{\pi \cdot l_d \cdot \rho_f}}, \quad (2.1)$$

being  $m$  the mass,  $l_d$  the developed length and  $\rho_f$  the fiber density.

#### 2.1.3 Aspect ratio

(1)P The aspect ratio is defined as the ratio of the length,  $l_f$ , to the equivalent diameter of the fiber,  $d_f$ .

### 2.1.4 Tensile strength of fiber

(1)P The tensile strength of the fiber is the stress corresponding to the maximum tensile force the fiber can bear.

(2) The tensile strength shall be calculated, in accordance to specific reference codes, by dividing the maximum force by the equivalent area of the cross-section, defined as the area of the circle with the diameter equal to  $d_f$ .

Reference values of the tensile strength are given in Table2-1 and Table2-2 for several different types of fiber.

### 2.1.5 Modulus of elasticity

(1) The modulus of elasticity of the fiber shall be evaluated in accordance to specific reference codes.

Reference values of the modulus of elasticity are given in Table 2-2 for several different types of fibers.

## 2.2 STEEL FIBERS

(1) The steel fibers have a length,  $l_f$ , usually ranging from 6 mm to 70 mm and an equivalent diameter,  $d_f$ , ranging from 0.15 mm to 1.20 mm.

(2) The steel fibers can be classified on the basis of the production process, the shape as well as the material.

- 1 Production process:
  - cold-drawn wire (Type A);
  - cut sheet (Type B);
  - other processes (Type C).
- 2 Shape:
  - straight;
  - deformed (hooked, crimped, etc.).
- 3 Material:
  - steel with low carbon content ( $C \leq 0.20$ , Type 1);
  - steel with high carbon content ( $C > 0.20$ , Type 2);
  - stainless steel (Type 3).

Based on the mechanical properties, fibers can be further classified into three different classes (R1, R2, R3) of Table 2-1.

**Table 2-1** – Strength classes of steel fibers.

Equivalent diameter [mm]	Minimum tensile strength [N/mm <sup>2</sup> ]												Alternated bending test
	R1				R2				R3				
	1)		2)		1)		2)		1)		2)		
	$R_m$	$R_{p0.2}$	$R_m$	$R_{p0.2}$	$R_m$	$R_{p0.2}$	$R_m$	$R_{p0.2}$	$R_m$	$R_{p0.2}$	$R_m$	$R_{p0.2}$	Not failure
$0.15 \leq d_f < 0.50$	400	320	480	400	800	720	1080	900	1700	1360	2040	1700	
$0.50 \leq d_f < 0.80$	350	280	450	350	800	640	1040	800	1550	1240	2015	1550	
$0.80 \leq d_f \leq 1.20$	300	240	390	300	700	560	910	700	1400	1120	1820	1400	

1) For straight fibers  
2) For shaped fibers

In Table 2-1,  $R_m$  e  $R_{p0.2}$  are the tensile strengths corresponding to the maximum force and a shift from the proportional behaviour with irreversible positive strain equal to 0.2% of the base length of the strain-gauge.

(3) The modulus of elasticity of steel fibers can be assumed equal to 200 GPa for steel with low and high carbon contents and equal to 170 GPa for stainless steel.

## **2.3 POLYMERIC AND CARBON FIBERS**

(1) Polymeric fibers made of acrylic, aramid, nylon, polyester, polyethylene, polypropylene, and carbon fibers are commercially available.

(2) The fibers can be used for improving:

- 1 the short term plastic properties;
- 2 the durability and the resistance to freezing and thawing cycles;
- 3 impact and abrasion resistance;
- 4 post-cracking resistance of cementitious matrixes;
- 5 fire resistance.

(3) Fibers can be classified into micro-fibers, with lengths of millimetres, and macro-fibers with a length up to 80 mm. Typical values of the aspect ratios range from 100 to 500.

(4) The main properties of the polymeric and carbon fibers, commercially available, are reported in Table 2-2.

Table 2-2 – Properties of polymeric and carbon fibers

Fibre type	Equivalent diameter [10 <sup>-3</sup> mm]	Density [g/mm <sup>3</sup> ]	Tensile strength [MPa]	Elastic modulus [MPa]	Ultimate strain [%]	Ignition temperature [°C]	Melting-oxidation/ decomposition temperature [°C]	Water absorption * [% in weight]
Acrylic	12.7-104.14	1.16-1.18	269-1000	13790-19306	7.5-50	-	221-235	1.0-2.5
Aramid I	11.94	1.44	2930	62055	4.4	High	482	4.3
Aramid II	10.16	1.44	2344	117215	2.5	High	482	1.2
Carbon, PAN HM	7.62	1.6-1.7	2482-3034	379914	0.6-0.7	High	400	Nil
Carbon, PAN HT	8.89	1.6-1.7	3447-3999	230293	1.0-1.5	High	400	Nil
Carbon, pitch GP	9.91-12.95	1.6-1.7	483-793	27580-34475	2.0-2.4	High	400	3-7
Carbon, pitch IIP	8.89-17.78	1.80-2.15	1517-3103	151690-482650	0.5-1.1	High	500	Nil
Nylon	22.86	1.14	965	5171	20	-	200-221	2.8-5.0
Polycster	19.81	1.34-1.39	227-1103	17237	12-150	593	257	0.4
Polyethylene	25.4-1016	0.92-0.96	76-586	4999	3-80	-	134	Nil
Polypropylene	-	0.90-0.91	138-689	3447-4826	15	593	165	Nil
Polyvinyl alcohol	14-600	1.30	880-1600	25000-40000	6-10	-	-	4.0

\* Agreement with standard (ASRM D570).



## **2.4 MATRIX**

- (1)P. FRC matrix is composed of cementitious materials (concrete or mortar)
- (2) In order to obtain a good dispersion of fiber as well as a proper workability, the mix of the matrix has to be correctly designed, for instance by increasing the amount of small aggregate particles.
- (3) The physical and mechanical properties of the concrete or mortar matrix are defined in accordance to specific reference standards.

## **2.5 FIBER REINFORCED CONCRETE**

- (1)P The physical and mechanical properties of the composite material depend on the proportions of the components as well as the properties of each component (cementitious matrix and fibers)
  - (2) The addition of fibers can improve the toughness, durability, impact resistance (resiliency), fatigue and abrasion resistance of the cementitious matrix.
  - (3) The mechanical properties of the fiber reinforced must be directly determined on specimens through standardized tests.
- (2)P The minimum volume fraction of the fibers for structural applications must not be less than 0.3%
- (4) Without specific tests, all the mechanical properties, not specified, can be assumed as those of ordinary concrete.

### **2.5.1 Fresh State Properties**

#### **2.5.1.1 Rheological properties**

- (1)P The rheological properties of fiber reinforced concrete depend on the consistency of the matrix as well as the fiber nature, dosage and geometry.
- (2) The use of fiber contents typical for structural applications, reduces the workability of the mix, especially for fibers with a complex shape and large aspect ratios. Appropriate modifications of the mix composition may be carried out where necessary:
  - by increasing the fine aggregate fraction and/or by reducing the maximum aggregate size;
  - by using an appropriate type and amount of superplasticizer.

#### **2.5.1.2 Homogeneity of the mix**

- (1)P Fiber distribution in the mix should be uniform. In order to achieve this condition, particular attention must be paid to avoid fiber agglomeration (balling). Even though the amount of these agglomerations is limited, their presence can cause some obstructions and make pumping difficult.
- (2) The homogeneity of the mix may be measured by checking the fiber content in some samples taken during the casting operation in accordance to EN 14721.

(3) The more diffused the regions with heterogeneous distributions of fibers, the more diverse the properties of the fiber reinforced concrete are from the nominal ones.

(4) Particular attention must be paid to carbonation phenomenon, especially when using a matrix composed of mortar and fibers.

### 2.5.1.3 Plastic shrinkage

(1)P The size of the plastic shrinkage cracking is reduced by the fibers.

(2) Polymeric microfibers (polypropylene) are more suitable for this purpose.

## 2.5.2 Mechanical properties hardening state

### 2.5.2.1 Compressive behaviour

(1)P Fibers generally reduce the brittleness of the matrix, but they do not have significant effect on the compressive behaviour.

(2) In practice, the constitutive law of fiber reinforced concrete can be assumed equal to that of ordinary concrete.

### 2.5.2.2 Tensile behaviour

(1)P Fibers improve the tensile behaviour of the cracked matrix, as schematically shown in Figure 2-1:

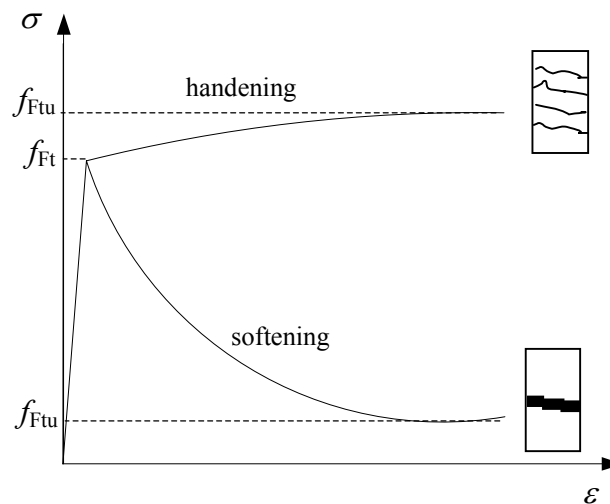

**Figure 2-1** – Tensile behaviour.

(2) For low fiber content (with volume fractions approx. lower than 2%), the behaviour is softening.

(3) For large fiber content (with volume fractions higher than 2%), the strength can be higher than the matrix one, since a hardening behaviour connected to multi-cracking phenomenon may occur (Figure 2-1).

(4) The uniaxial first crack tensile strength of fiber reinforced concrete,  $f_{Ft}$ , may be assumed equal to that of the matrix,  $f_{ct}$ . For softening behaviour material, the strength,  $f_{Ft}$ , may be assumed equal to the maximum stress (Figure 2-1).

(5) The residual uniaxial tensile strength of the material,  $f_{Ftu}$  (Figure 2-1), is significantly affected by the volume fraction of fibers,  $V_f$ , by the aspect ratio,  $l_f/d_f$ , as well as the bond between concrete and steel, for both the cases (softening and hardening behaviour).

This statement may be easily deduced from the equilibrium in the direction at right angle with the fracture surface, assuming fibers parallel to this direction and evaluating the pull-out specific force ( $Q$ ) as:

$$Q = n_f \cdot \pi \cdot d_f \cdot l_b \cdot \tau_m = \omega \cdot \frac{V_f}{A_f} \cdot \pi \cdot d_f \cdot l_b \cdot \tau_m = \omega \cdot V_f \cdot \frac{l_f}{d_f} \cdot \tau_m, \quad \dots\dots(2.1)$$

where:

- $n_f$  is the number of fibers in the unit of fracture area;
- $d_f$  is the equivalent diameter of the fiber;
- $l_b = l_f/4$  is the conventional bond length of every fiber;
- $\tau_m$  is the mean tangential bond stress
- $\omega$  is a coefficient taking into account the real orientation of the fibers;
- $V_f$  is the volume fraction of the fibers;
- $A_f$  is the area of the cross section of a single fiber.

The equation (1.1) provides an approximate value, since it does not take into account other factors, e.g. fiber shape, fiber-matrix interface, casting direction, mixing and compaction technique of the fresh concrete that affects fiber distribution and orientation in the matrix.

(6) As a result, a performance approach, able to experimentally identify the constitutive tensile curve by means of appropriate tests on fiber reinforced concrete specimens is suggested.

The nominal stress – crack opening law,  $\sigma_N-w$ , may be determined through uniaxial tension or bending tests.

The uniaxial tension test directly provides the  $\sigma-w$  law and may be performed in accordance to UNI 11188.

For softening behaviour material, the execution of this test is not simple. Thus, the bending test may be performed in accordance to UNI 11039 (Figure 2-2).

In this case, the nominal stress is evaluated assuming an elastic behaviour of the specimen (with reference to Figure 2-2:  $\sigma_N=6 \cdot P \cdot l / b \cdot h^2$ ).

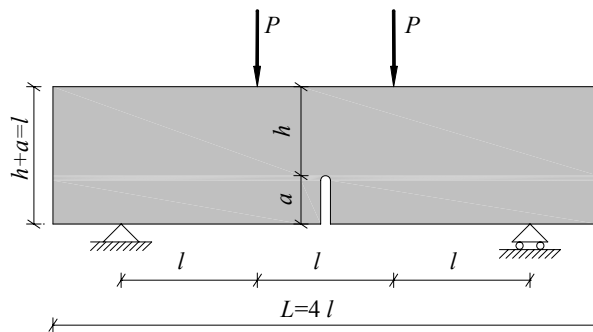

**Figure 2-2** – Four point bending test as suggested in UNI 11039.

(7) The  $\sigma$ - $w$  law, deduced from a bending test and carried out using the procedures reported in Appendix A, may be directly used to analyse structural elements subjected to bending. For elements subjected to simple tension, the strength must be reduced through a coefficient equal to 0.7.

When a notched specimen has a hardening behaviour resulting from a bending test, the test must be repeated on an un-notched specimen in order to verify the real ductility.

The bending test on an un-notched specimen should also be performed on thin walled elements subjected to bending in order to take into account significant variables such as the casting direction, the mixing technique and the wall effect (Appendix A).

(8) The post-cracking strength may be defined on the basis of point values,  $f_i$ , corresponding to specified nominal value of crack opening, or on mean values,  $f_{eqi}$ , calculated for assigned intervals of crack opening (Figure 2-3). When a notched specimen is considered, the crack opening may be conventionally assumed equal to the displacement between two points at the notch tip, CTOD.

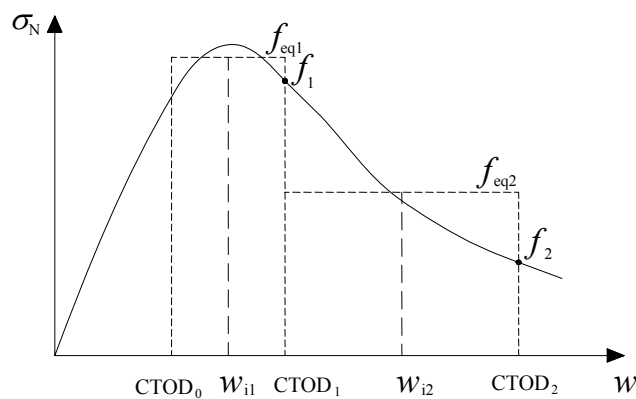

**Figure 2-3** – Definition of point and mean residual strength.

(9) Two simplified stress-crack opening constitutive laws may be deduced on the basis of the bending test results: a linear post-cracking behaviour (hardening or softening) or a plastic rigid behaviour, as schematically shown in Figure 2-4. In the latter,  $f_{Fts}$  represents the serviceability residual strength, defined as the post-cracking strength for serviceability crack openings, whereas  $f_{Ftu}$  represents the ultimate residual strength.

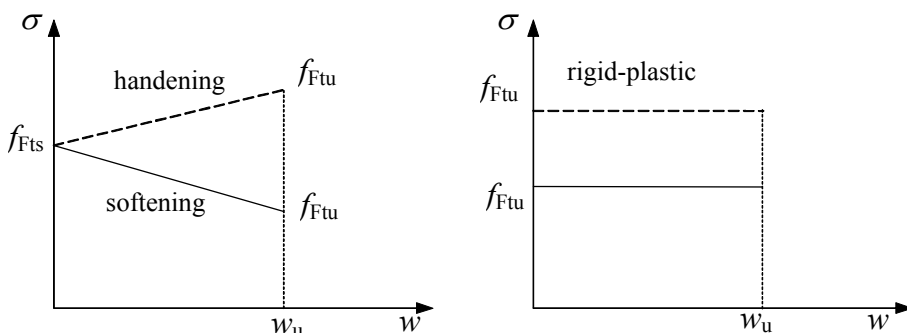

**Figure 2-4** – Simplified constitutive laws: tension-crack opening.

(10) The stresses,  $f_{Fts}$  e  $f_{Ftu}$ , characterizing these two models may be evaluated through the procedure reported in Appendix A.

(11) When considering a softening behaviour materials, the ultimate crack opening value,  $w_u$ , of the constitutive law cannot be greater than the maximum value of 3 mm for elements subjected to bending, and 1.5 mm, for elements subjected to tension.

(12) When hardening behaviour materials are considered, and multi-cracking occurs, the identification of crack openings is not necessary because a stress-strain law may be directly used, as specified later.

(13) More complex alternative methods, suggested in literature, may be used provided that they are validated.

### 2.5.2.3 Stress-strain constitutive law

The previously suggested constitutive laws are expressed in terms of stress and strain.

(1) When considering softening behaviour materials, the definition of the stress-strain law is based on the identification of the crack opening width as well as the corresponding characteristic length  $l_{cs}$  of the structural element. Thus, the strain can be assumed equal to:

$$\varepsilon = w / l_{cs}. \quad (2.2)$$

Characteristic length  $l_{cs}$  may be evaluated in the presence of a conventional reinforcement through the following equations:

$$l_{cs} = \min \{s_{rm}, y\}, \quad (2.3)$$

$$s_{rm} = \xi \cdot \left( 50 + 0.25 \cdot k_1 \cdot k_2 \cdot \frac{\phi}{\rho} \right) \quad [\text{length in mm}], \quad (2.4)$$

where:

- $s_{rm}$  mean distance value between cracks;
- $y$  distance between neutral axis and the extreme tensile side of the cross section, evaluated in the elastic cracked phase with no tensile strength of the fiber reinforced;
- $\xi$  adimensional coefficient equal to 1.0 when  $l_f / d_f < 50$ , equal to  $50 \cdot d_f / l_f$  when  $50 \leq l_f / d_f \leq 100$  and equal to 1/2 when  $l_f / d_f > 100$ ;
- $d_f$  fiber diameter;
- $l_f$  fiber length;
- $\phi$  bar diameter (when different bar are used in a section, the weighted average carried put on the cross section of each bar can be used);
- $k_1$  is 0.8 for high bond bars, 1.6 for smooth bars;
- $k_2$  is 0.5 by pure or composite bending when  $y \leq h$ , is 1.0 for tension or when  $y > h$ ;
- $h$  section height;
- $\rho$  geometric reinforcement ratio within the effective tension area, defined by the distance  $y$ .

In the case of sections without traditional reinforcement, subjected to bending, combined tensile – flexural and normal compressive – flexural forces with resulting force external to the section,  $y = h$  is assumed);

- (2) The above mentioned modalities, useful in obtaining the characteristic length, are connected with the plane-section beam model. For a different cinematic model, (e.g. Finite element method), these modalities must be redefined.
- (3) When considering a hardening behaviour material, multi-cracking occurs. Thus, a mean strain may be directly obtained from the experimental tests, useful in identifying the constitutive parameters. The ultimate strain value is assumed equal to 1%.
- (4) Finally, the tensile stress - strain behaviour may be assumed as shown in Figure 2-5, using the parameters reported in Appendix A.

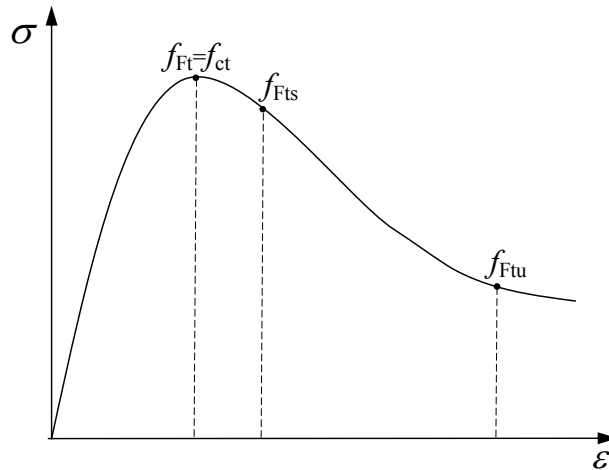

Figure 2-5 – Stress-strain law.

- (5) Simplified models (Figure 2-6), corresponding to tension-crack opening laws shown in Figure 2-4, may be used. The first one is based on serviceability and ultimate equivalent residual strengths. The second one, rigid plastic model, is based on an appropriate value of the ultimate residual strength. These laws only concern the residual post-cracking strengths.

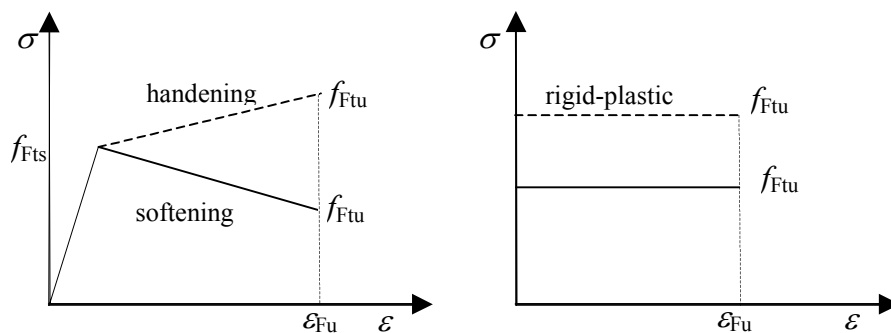

Figure 2-6 – Simplified stress-strain constitutive laws.

**2.5.2.4 Modulus of elasticity**

- (1) Modulus of elasticity is not generally affected by fibers, so it may be assumed equal to that of the matrix.

### **2.5.3 Physical properties at hardened state**

#### **2.5.3.1 Drying shrinkage**

(1) The presence of fibers reduces crack width caused by drying shrinkage.

#### **2.5.3.2 Freezing and thawing resistance**

(1) Neither the resistance of concrete to freezing and thawing cycles nor resistance to de-icing salt is significantly affected by the presence of fibers. As a matter of fact, no important increase of spalling is noted in fiber reinforced concrete.

#### **2.5.3.3 Penetration of aggressive ions**

(1) The effects of fibers on diffusion phenomena in concrete are currently not well-known. Generally, no negative effects about aggressive ion transportation may be noted in good quality fiber reinforced concrete.

#### **2.5.3.4 Carbonation**

(1) The presence of fibers does not significantly affect the carbonation phenomena because no appreciable increase of the carbonation depth has been observed.

#### **2.5.3.5 Fiber corrosion**

(1) When using steel fibers in concrete, some localized efflorescence of iron oxide can occur. This phenomenon is only an aesthetic problem and it may be prevented by using zinc treatment or stainless steel fibers.

#### **2.5.3.6 Fire resistance**

(1) The research dealing with fire behaviour of steel fiber reinforced concrete suggests the following considerations:

- Low percentages of fiber (up to 1%) do not significantly affect the thermal diffusivity, which may still be calculated with reference to the matrix data.
- Material damage resulting from a thermal cycle up to 800 °C is mainly related to the maximum cycle temperature and produces an irreversible effect on the matrix. This phenomenon is observed when limited amounts of fibers are used, the damage of the material may be evaluated through the residual strength measured at room temperature.
- Varying the maximum exposition temperature, first cracking strength is similar to the matrix one. For temperatures higher than 600 °C, fibers improve the matrix behaviour.
- Varying the maximum exposition temperature, the fiber reinforced concrete modulus of elasticity is not significantly affected by the presence of limited volume fractions ( $\leq 1\%$ ) of fiber, thus, it may be considered equal to that of the matrix.

(2) The presence of polypropylene fiber is useful in limiting spalling effects. In particular, this kind of fiber partially sublimates at 170 °C, leaving free cavities in the matrix. A volume fraction of fibers between 0.1% and 0.25% is able to either reduce or eliminate spalling.

## **2.6 STEEL**

(1)P The steel properties of reinforcement bars and their constitutive laws must correspond to those reported in currently used standards.

### 3 DESIGN BASIC CONCEPTS AND SPECIAL PROBLEMS

#### 3.1 GENERAL

(1)P This chapter deals with fiber reinforced concrete (FRC) structures, either in the presence or without traditional reinforcement.

(2)P The design must fulfill resistance and serviceability requirements for the working life of the fiber reinforced concrete structures.

(3) For structural applications of FRC with softening behaviour, the following relationship must be fulfilled:

$$f_{Ftsk}/f_{ctk} > 0.2. \quad (3.1)$$

(4) In all FRC structures the following condition has to be satisfied:

$$\alpha_u \geq 1.2 \cdot \alpha_1, \quad (3.2)$$

where  $\alpha_u$  is the maximum load and  $\alpha_1$  is the first cracking load (typical values of  $\alpha_u$  and  $\alpha_1$  are shown in Annex D).

(5) Structural elements made of FRC can be cast without any traditional reinforcement. In the case of mono-dimensional elements, in addition to the limitations (3) and (4), the FRC adopted must have a hardening behaviour under tension, with the following restrictions:

- $(f_{Ftu}/f_{Fts})_k > 1.05$ ;
- $(f_{Ftu}/f_{Fts}) \geq 1$ , with reference to the single test.

#### 3.2 BASIC REQUIREMENTS

(1)P Based on the assumption of the Building Codes, a FRC structure shall be designed in order to satisfy, during its expected life, the following fundamental requirements:

- it will sustain all actions expected to occur, and
- it will guarantee an adequate durability in order to control the maintenance costs.

(2)P A FRC structure shall be designed and construed in such a way that it will not be damaged by events such as explosions, impacts, and consequences of human errors, to an extent disproportionate to the original cause.

(3) Potential damage shall be avoided or limited by appropriate choice of one or more of the following items:

- avoiding, eliminating or reducing the hazards to which the structure can be subjected;
- selecting a structural form which has low sensitivity to the hazards considered ;
- selecting a structural form and design that can adequately survive the accidental removal of an individual member or a limited part of the structure.



(4)P The basic requirements should be met :

- by the choice of suitable materials;
- by appropriate design and detailing;
- by specifying control procedures for the production of FRC, and the design and execution of the structure.

### **3.3 DESIGN SERVICE LIFE**

(1) The design working life should be specified in accordance to indicative categories.

### **3.4 GENERAL RULES FOR DESIGN**

#### **3.4.1 General**

(1)P The verification procedure of FRC elements shall be performed both in the case of the Serviceability Limit States (SLS) as well as the Ultimate Limit States (ULS), in accordance to the current Standard.

(2) Verification of one of the two categories of the limit states may be omitted provided that sufficient information is available to prove that it is satisfied by the other.

(3)P When using the partial factor method, it shall be verified that, in all significant design situations, no relevant limit state is exceeded when design values for actions or effects of actions and resistances are used in the design models, therefore:

$$E_d \leq R_d, \quad (3.3)$$

where  $E_d$  is the design values of the effects of actions and  $R_d$  is the design value of the corresponding resistance, for the limit state taken into account.

(4) The design values should be obtained by using the characteristic values, in combination with partial factors, in accordance to the current Standard and conveniently integrated in the present Standard as far as the tensile strength of FRC is concerned.

#### **3.4.2 Design values**

(1) The design value for a FRC element can be expressed in accordance to the current Standard.

#### **3.4.3 Material properties**

(1)P Material properties have to be determined, in the design of FRC structures, by means of standardized laboratory tests, as indicated in Chapter 2.

(2) The mechanical properties in terms of strength and deformation of the materials are quantified by means of characteristic values, as defined in § 3.5.

(3) Only the modulus of elasticity of materials are quantified in terms of mean values.

(4) The design value  $X_d$  of a material property can be expressed in general terms as:

$$X_d = \frac{X_k}{\gamma_m} \quad (3.4)$$

where  $X_k$  is the characteristic value of the generic property and  $\gamma_m$  is the partial factor for the material.

### 3.4.4 Design resistance

(1) The design resistance  $R_d$  can be expressed as follows:

$$R_d = \frac{1}{\gamma_{Rd}} \cdot R\{X_{d,i}; a_{d,i}\} = \frac{1}{\gamma_{Rd}} \cdot R \cdot \left\{ \frac{X_{k,i}}{\gamma_{m,i}}; a_{d,i} \right\}, \quad (3.5)$$

where  $R\{\cdot\}$  is a specific function related to the considered mechanical model (i.e. bending, shear, etc);

$\gamma_{Rd}$  is a partial factor covering uncertainties of the assumed model;

$X_{d,i}$  is the design value of the material property;

$a_{d,i}$  is the nominal value of the geometrical parameters involved in the model by considering the tolerances;

$\gamma_m$  is the partial factor for the material property.

## 3.5 CHARACTERISTIC VALUES OF MATERIAL STRENGTH

(1) The characteristic value of the compressive strength of FRC ( $f_F$ ) is to be determined in the same way as for the concrete matrix.

(2)P The characteristic value of the tensile strength of FRC ( $f_{Ftk}$ ) is related, beyond to the results of tests on suitable specimens, to the structure.

(3) The characteristic value of the tensile strength of FRC ( $f_{Ftk}$ ) can be determined from the mean value ( $f_{Ftm}$ ) as follows:

$$f_{Ftk} = f_{Ftm} - \alpha \cdot k \cdot s, \quad (3.6)$$

where  $s$  is the standard deviation and  $k$  is a function of the number of specimens.

The  $\alpha$  coefficient considers the effects of structural statical indeterminacy, as shown in Appendix D.

A typical value of  $\alpha$  and  $k$  is shown in Appendix D.

## 3.6 PARTIAL SAFETY FACTORS

### 3.6.1 Partial Safety Factors for materials

(1) The recommended values of the partial factors for the ultimate limit states are shown in Table 3-1

(2) The partial factors for serviceability limit states should be taken as 1,0.

**Table 3-1 – Partial Factors.**

Material	Applications type A <sup>(1)</sup>	Applications type B <sup>(2)</sup>
FRC in compression	According to current standard	According to current standard
FRC in tension	According to current standard	According to current standard
FRC in tension (residual strength)	$\gamma_F = 1.5$	$\gamma_F = 1.3$
Steel	According to current standard	According to current standard

(1) Ordinary quality control on materials; strength values obtained from standard test (Appendix B).

(2) High quality control on materials as well on structures; strength values obtained from specific structural test (Appendix B).

Remark: the value of partial factors of FRC under tension  $\gamma_F$ , is lower than that related to compression  $\gamma_c$ , as it refers to a residual strength not to the peak one.

### 3.6.2 Partial factors $\gamma_{Rd}$ for the resistance models

(1) According to resistance models (Chapter 4), the partial factors for the ultimate limit states  $\gamma_{Rd}$  should be taken as 1,0.

## 3.7 DURABILITY REQUIREMENTS

(1) In order to ensure that FRC structures are durable, the following key-points have to be considered:

- the use of the structure as expected;
- the environmental conditions that the structure will be exposed to;
- the composition, properties and performance of all the components (concrete matrix, fibers, steel);
- structural details;
- the degree of control;
- special protection features such as fire;
- maintenance expected during the working life.

(2) With regard to the general durability requirements of FRC structural elements and their corresponding design and production criteria, the specifications given in UNI EN 12390-8 (water penetration test under pressure) shall apply.

(3) The following exposure class (UNI EN 206-1) shall be considered:

- X0 – No risk of corrosion or attack (for concrete in very dry environmental conditions);
- XC – Corrosion induced by carbonation;
- XD – Corrosion induced by chlorides (not for chlorides from sea water);
- XS – Corrosion induced by chlorides from sea water;
- XF – Freeze/Thaw Attack;
- XA – Chemical attack.

(4) Table 3-2 provides recommendations for selecting the fiber type depending on the exposure class as well as the concrete matrix (only for steel fibers). Fibers can be classified by means of a letter and a number.

In particular, the letter refers to the production process (§ 2.2):

- A: fiber from wire;

- B: fiber from strip;
- C: other fiber.

The number refers to the chemical composition of the fiber:

- 1: low carbon content;
- 2: high carbon content;
- 3: inox.

The term ST indicates the possible presence of surface treatment.

**Table 3-2** – Recommendations in the choice of steel fibers according to the exposure class as well as the type of concrete.

Type of concrete	Type of fibre	Exposure classes																	
		No risk of corrosion or attack	Corrosion induced by carbonation				Corrosion induced by chlorides						Freeze/Thaw attack				Aggressive chemical environment		
							Other chlorides (different from sea water)			Sea water									
X0	XC1	XC2	XC3	XC4	XD1	XD2	XD3	XS1	XS2	XS3	XF1	XF2	XF3	XF4	XA1	XA2	XA3		
C1	A3-B3-C3	YES	YES	YES	YES	YES	YES	YES	YES	YES	YES	YES	YES	YES	YES	YES	YES	YES	
	A1-B1-C1 ST	YES	YES	YES	YES	YES	YES	YES	YES	YES	YES	YES	YES	YES	YES	YES	YES	YES	
	A1-B1-C1	YES	YES	YES	YES	-	YES	YES	-	YES	-	-	YES	YES	YES	-	-	-	
	A2-B2-C2 ST	YES	YES	YES	YES	YES	YES	YES	YES	YES	YES	-	YES	YES	YES	YES	-	-	
C2	A2-B2-C2	YES	YES	YES	-	-	YES	-	-	-	-	-	-	-	-	-	-	-	
	A3-B3-C3	YES	YES	YES	YES	YES	YES	YES	YES	YES	YES	YES	YES	YES	YES	YES	YES	-	
	A1-B1-C1 ST	YES	YES	YES	YES	YES	YES	YES	YES	YES	YES	YES	YES	YES	YES	YES	YES	-	
	A1-B1-C1	YES	YES	YES	YES	-	YES	YES	-	YES	-	-	YES	-	-	-	-	-	
	A2-B2-C2 ST	YES	YES	YES	YES	YES	YES	YES	-	YES	YES	-	YES	-	-	-	-	-	
C3	A2-B2-C2	YES	YES	YES	-	-	-	-	-	-	-	-	-	-	-	-	-	-	
	A3-B3-C3	YES	YES	YES	YES	YES	YES	YES	YES	YES	YES	-	YES	-	-	-	YES	-	
	A1-B1-C1 ST	YES	YES	YES	YES	YES	YES	-	-	-	-	-	-	-	-	-	-	-	
	A1-B1-C1	-	-	-	-	-	-	-	-	-	-	-	-	-	-	-	-	-	
	A2-B2-C2 ST	YES	YES	YES	YES	YES	YES	-	-	-	-	-	-	-	-	-	-	-	
C3	A2-B2-C2	-	-	-	-	-	-	-	-	-	-	-	-	-	-	-	-	-	

- (5) There are currently no indications available for synthetic and carbon fibers.
- (6) Matrix classification refers to concrete impermeability, identified through water penetration test under pressure, in accordance to UNI ENV 206.  
The matrix is considered:
- type C1 if the maximum value of water penetration is lower than 20 mm and the mean value is not greater than 10 mm;
  - type C2 if the maximum value is lower than 50 mm and the mean value is not greater than 20 mm;
  - type C3 in all other cases.
- (7) The use of the recommendations of Table 3-2 in design ensures the production of durable structural elements over a service life for at least 50 years under ordinary service conditions.
- (8) If other combinations or longer service life are considered, the designer has to give special indications about the specific project. In such cases the section considered in the design shall be reduced by at least 10 mm (the section is to be evaluated case by case) for each side exposed to external attacks in comparison with the actual production.

(9) For structural FRC elements the values of the crack opening is limited by the introduction of fibers into the matrix. The values of the cover may also be properly reduced in accordance to any Standard for structures made of traditional concrete, as indicated in § 6.3.2(2).

(10) The use of fibers in polyethylene or polyvinyl alcohol in volume percentages greater than 2% may reduce the crack opening ( $\leq 60 \mu\text{m}$ ) even for significant values of deformation ( $\approx 1\%$ ). For such values of crack widths, the concrete can be considered uncracked in terms of durability.

## 4 ULTIMATE LIMIT STATES (ULS) VERIFICATION

### 4.1 ULS FOR MONO-DIMENSIONAL ELEMENTS

#### 4.1.1 General

(1)P The ULS design requires the evaluation of the ultimate bending moment resistance as well as the comparison with the design value of the applied bending moment.

(2)P The fundamental hypotheses for the ULS analysis of FRC sections are:

- sections remain plane up to the ultimate state (to linear strain distribution);
- perfect bond between the rebars and the surrounding FRC;
- the stresses in the FRC are derived from the design stress/strain relationship given in §§ 2.5.2.2 and 2.5.2.3;
- the stress/strain relationships reinforcing or prestressing steel, if present, are derived from the current Codes.

(3)P The bending failure is considered when one of the following conditions is obtained:

- attainment of the maximum compressive strength,  $\varepsilon_{cu}$ , in FRC;
- attainment of the maximum tensile strength  $\varepsilon_{su}$ , in steel (if present);
- attainment of the maximum tensile strength,  $\varepsilon_{Fu}$ , in FRC.

When a FRC with a softening behaviour is considered, the maximum tensile strain,  $\varepsilon_{Fu}$ , shall be considered equal to 2%. The ultimate value of the crack opening,  $w_u$ , shall satisfy in all cases the limitation:  $w_u = \varepsilon_u \cdot l_{cs} \leq 3$  mm.

The corresponding tensile stress value (in the post peak branch) shall be considered as the ultimate value of the residual tensile stress.

When a FRC with a hardening behaviour is considered, the maximum tensile strain,  $\varepsilon_{Fu}$ , shall be considered equal to 1%.

#### 4.1.2 Bending with axial force

(1) For a fixed value of the applied design axial force,  $N_{Sd}$ , the ultimate bending moment,  $M_{Rd}$ , can be evaluated by means of the translation and rotation equilibrium equations.

(2) The evaluation of the ultimate moment can be carried out in reference to the strain and stress distributions shown in Figure 4-1, corresponding to the FRC stress/strain relationship reported in §§ 2.5.2.2 and 2.5.2.3 and reinforcement steel laws (if present) in accordance to the current Codes.

(3) With reference to the condition shown in Figure 4-1 and in accordance to Eurocode 2 (EC2) the evaluation of the ultimate moment for a given axial force can be made by adopting the simplified stress/strain relationship (that corresponds to the maximum compressive and post-peak tensile stress, see § 2.5.2.3), by verifying *a posteriori* so that the ultimate strains  $\varepsilon_{cu}$ ,  $\varepsilon_{su}$  and  $\varepsilon_{Fu}$  are not violated and the collapse mechanism respected.

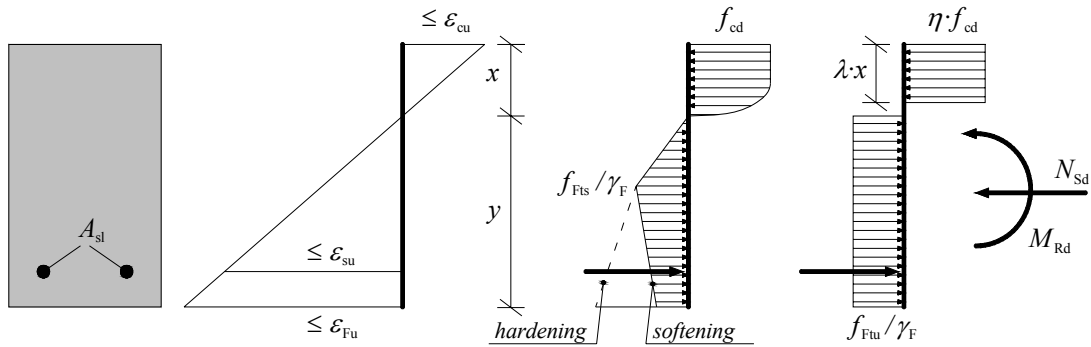

**Figure 4-1** – ULS for bending moment and axial force: use of the simplified stress/strain relationship (*stress-block* with  $\eta$  e  $\lambda$  coefficient in accordance with EC2).

### 4.1.3 Shear

#### 4.1.3.1 General

For the ULS verification of the shear resistance, the mono-dimensional members (beams) shall satisfy the prescriptions given in the following.

#### 4.1.3.2 Members without design shear and conventional longitudinal reinforcement

(1)P When FRCs with hardening tensile behaviour are used and members without both longitudinal and transverse reinforcement are considered, the principal tensile stress,  $\sigma_1$ , shall not be greater than the design tensile strength:

$$\sigma_1 \leq \frac{f_{Ftuk}}{\gamma_F} \quad (4.1)$$

(2)P In members without either longitudinal or transverse reinforcement, FRCs with softening behaviour shall not be used.

#### 4.1.3.3 Members without design shear reinforcement, with conventional longitudinal reinforcement

(1)P The design value for the shear resistance in members with conventional longitudinal reinforcement and without shear reinforcement is given by:

$$V_{Rd,F} = \left\{ \frac{0.18}{\gamma_c} \cdot k \cdot \left[ 100 \cdot \rho_l \cdot \left( 1 + 7.5 \cdot \frac{f_{Ftuk}}{f_{ctk}} \right) \cdot f_{ck} \right]^{1/3} + 0.15 \cdot \sigma_{cp} \right\} \cdot b_w \cdot d \text{ [stresses in MPa]} \quad (4.2)$$

where:

- $\gamma_c$  is the partial safety factor for the concrete matrix without fibers;
- $k$  is a factor that takes into account the size effect and equal to  $1 + \sqrt{\frac{200}{d}} \leq 2.0$ ;
- $d$  is the effective depth of the cross section;
- $\rho_l$  is the reinforcement ratio for longitudinal reinforcement and equal to  $\rho_l = A_{sl}/b_w d \leq 0.02$ ;
- $A_{sl}$  is the cross sectional area of the reinforcement which is bonded beyond the considered section;

- $f_{Ftuk}$  is the characteristic value of the ultimate residual tensile strength for the FRC, by considering  $w_u = 1.5$  mm (see Appendix A);
- $f_{ctk}$  is the characteristic value of the tensile strength for the concrete matrix in accordance to the current Codes;
- $f_{ck}$  is the characteristic value of cylindrical compressive strength in accordance to the current Codes;
- $\sigma_{cp} = N_{Ed}/A_c$  is the average stress acting on the concrete cross section,  $A_c$ , for an axial force  $N_{Ed}$  due to loading or prestressing actions (shall be considered positive compression stresses);
- $b_w$  is the smallest width of the cross-section in the tensile area.

The shear resistance  $V_{Rd,F}$ , is assumed not to be less than the minimum value,  $V_{Rd,Fmin}$ , defined as:

$$V_{Rd,Fmin} = (v_{min} + 0.15 \cdot \sigma_{cp}) \cdot b_w \cdot d, \quad (4.3)$$

where  $v_{min}$  is a coefficient equal to  $0.035 \cdot k^{3/2} \cdot f_{ck}^{1/2}$ .

(2) For members with loads applied on the upper side within a distance  $0,5d \leq a \leq 2d$  from the edge of a support (or centre of bearing where flexible bearings are used), the acting shear force may be reduced by  $\beta = a/(2 \cdot d)$ . This is only valid provided that the longitudinal reinforcement is fully anchored at the support. For  $a \leq 0,5d$  the value  $a = 0,5d$  should be used.

(3) When point loads close to the support or in diffusive regions are present, the verification can be carried out with *strut-and-tie* models.

The maximum shear resistance shall not be greater than the maximum shear force which can be sustained by the member, limited by the crushing of the compression struts.,  $V_{Rd,max}$ , defined in the following § 4.1.3.4 in Eq. 3.15.

#### 4.1.3.4 Members with shear and longitudinal conventional reinforcement

(1) The ultimate shear resistance,  $V_{Rd}$ , for FRC members with transverse reinforcement can be evaluated as the sum of a contribution due to the web reinforcement,  $V_{Rd,s}$ , and a contribution due to the fiber reinforcement,  $V_{Rd,F}$ :

$$V_{Rd} = V_{Rd,s} + V_{Rd,F} \quad (4.4)$$

$V_{Rd,s}$  can be evaluated as:

$$V_{Rd,s} = \frac{A_{sw}}{s} \cdot z \cdot f_{ywd} \cdot (\cot \psi + \cot \theta) \cdot \sin \psi, \quad (4.5)$$

where:

- $\theta$  is the angle between the concrete compression strut and the beam axis perpendicular to the shear force, equal to  $45^\circ$  if prestressing action is not present;
- $\psi$  is the angle between shear reinforcement and the beam axis perpendicular to the shear force
- $z$  is the inner lever arm, for a member with constant depth, corresponding to the bending moment in the element under consideration. In the shear analysis of reinforced concrete without axial force, the approximate value  $z = 0,9d$  may be used;



- $A_{sw}$  is the cross-sectional area of the conventional shear reinforcement;
- $s$  is the spacing of the conventional shear reinforcement;
- $f_{ywd}$  is the design yield strength of the shear reinforcement.

In Equation (4.5), the cross-sectional area of the conventional shear reinforcement,  $A_{sw}$ , shall not be greater than:

$$A_{sw,max} \leq \frac{0.5 \cdot \nu \cdot f_{cd} \cdot \sin \psi}{1 - \cos \psi} \cdot \frac{b_w \cdot s}{f_{ywd}}, \quad (4.6)$$

where  $\nu$  a strength reduction factor for concrete cracked in shear, that can be assumed equal to:

$$\nu = 0.6 \cdot \left(1 - \frac{f_{ck}}{250}\right) \quad [f_{ck} \text{ in MPa}]. \quad (4.7)$$

In all cases, the maximum shear resistance shall not be greater than the maximum shear force which can be sustained by the member, limited by the crushing of the compression struts.,  $V_{Rd,max}$ , defined as:

$$V_{Rd,max} = \frac{b_w \cdot z \cdot \nu \cdot f_{cd} \cdot (\cot \psi + \cot \theta)}{(1 + \cot^2 \theta)}. \quad (4.8)$$

#### 4.1.3.5 Minimum shear reinforcement

(1) It is possible to avoid the presence of conventional shear reinforcement (stirrups) if the following limitation is respected:

$$f_{Ftuk} \geq \frac{\sqrt{f_{ck}}}{20} \quad [f_{ck} \text{ in MPa}]. \quad (4.9)$$

This limitation allows limiting the development and the diffusion of the inclined cracking and, as a consequence, can ensure a sufficient member ductility.

(2) When the above-mentioned limitation is violated, a conventional shear reinforcement (stirrups) shall be introduced, sufficient to ensure an ultimate shear resistance greater than the first cracking one,  $V_{cr}$ :

$$V_{cr} = 0.67 \cdot f_{ctk} \cdot b_w \cdot d. \quad (4.10)$$

The part of the shear resistance due to the shear reinforcement is equal to the difference:

$$V_{Rds,min} = V_{cr} - V_{Rd,F}. \quad (4.11)$$

(3) The longitudinal spacing between the shear reinforcements (stirrups),  $s$ , shall not exceed the value  $0.8 \cdot d$ .

(4) When a great amount of longitudinal reinforcement in the compressive zone is present, adequate stirrups reinforcement shall be applied in order to prevent rebar instability.

#### 4.1.4 Torsion

##### 4.1.4.1 Members without torsional longitudinal and transverse conventional reinforcement

(1)P When FRCs with hardening tensile behaviour are used and members without longitudinal rebars and transverse reinforcement are considered, the principal tensile stress,  $\sigma_1$ , shall not be greater than the design tensile strength:

$$\sigma_1 \leq \frac{f_{Ftuk}}{\gamma_F}. \quad (4.12)$$

##### 4.1.4.2 Members with torsional longitudinal and transverse conventional reinforcement

(1) When members with longitudinal rebars and transverse reinforcement are considered, the contribution of fiber reinforcement can be taken into account based on adequate models.

## 4.2 PLATE ELEMENTS

### 4.2.1 Plate elements without conventional reinforcement

(1) For bi-dimensional plane FRC elements loaded along the mean plane (plate) (Figure 4-2), the resistance verification shall be carried out with reference to the nominal stresses,  $n_x$  and  $n_y$ , and the tangential stresses,  $n_{xy}$ , considered positive if direct as indicated in Figure 4-2.

The related nominal principal stresses,  $n_1$  ed  $n_2$  ( $<n_1$ ), can be determined by the following relationships, assuming as positive the tensile stresses:

$$n_1 = \frac{1}{2} \cdot \left[ (n_x + n_y) + \sqrt{(n_x - n_y)^2 + 4 \cdot n_{xy}^2} \right], \quad (4.13)$$

$$n_2 = \frac{1}{2} \cdot \left[ (n_x + n_y) - \sqrt{(n_x - n_y)^2 + 4 \cdot n_{xy}^2} \right]. \quad (4.14)$$

For the resistance verification, when  $n_1 \geq 0$ , the following relationships shall be verified:

$$n_1 \leq f_{Ftud} \cdot t \quad \text{for } (-0.3 \cdot f_{Fd} \cdot t) \leq n_2 \leq (f_{Ftud} \cdot t), \quad (4.15)$$

$$n_1 \leq f_{Ftud} \cdot \left( \frac{f_{Fd} \cdot t + n_2}{0.7 \cdot f_{Fd}} \right) \quad \text{for } (-f_{Fd} \cdot t) \leq n_2 \leq (-0.3 \cdot f_{Fd} \cdot t), \quad (4.16)$$

being:

$$f_{Ftud} = \frac{f_{Ftuk}}{\gamma_F}; \quad f_{Fd} = \frac{f_{ck}}{\gamma_c}. \quad (4.17)$$

For  $n_1 < 0$ , the resistance verification becomes:

$$-f_{Fd} \cdot t \leq n_2 \leq n_1 \leq 0. \quad (4.18)$$

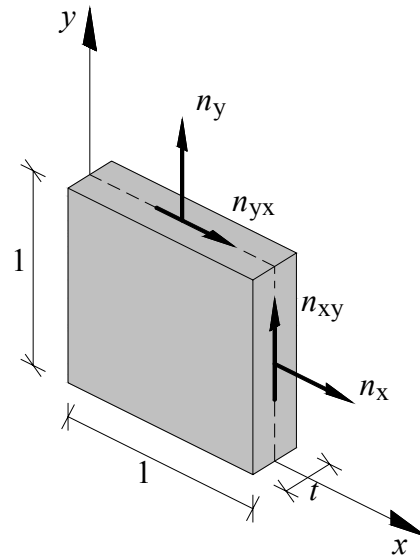

**Figure 4-2 – Plane stress field.**

(2) When FRC materials with hardening behaviour are adopted the Serviceability Limit State verification is required.

#### 4.2.2 Plate elements with conventional reinforcement

(1) For FRC plate elements, defined as in § 4.2.1 and with rebars at right angles placed along  $x$  and  $y$  axes (Figure 4-2) having a cross section for unit width,  $a_{sx}$  e  $a_{sy}$  respectively, the resistance verification requires the satisfaction of the following relationships

$$\left( -a_{sx} \cdot f_{sd} - f_{Fd} \cdot t + \frac{n_{xy}}{\lambda} \right) \leq n_x \leq \left( a_{sx} \cdot f_{sd} + f_{Ftud} \cdot t - n_{xy} \cdot \lambda \right), \quad (4.19)$$

$$\left( -a_{sy} \cdot f_{sd} - f_{Fd} \cdot t + n_{xy} \cdot \lambda \right) \leq n_y \leq \left( a_{sy} \cdot f_{sd} + f_{Ftud} \cdot t - \frac{n_{xy}}{\lambda} \right), \quad (4.20)$$

$$|n_{xy}| \leq \frac{(f_{Fd} + f_{Ftud}) \cdot t \cdot |\lambda|}{1 + \lambda^2}, \quad (4.21)$$

where, considering  $n_x > n_y$ , it is :

$$\lambda = \frac{2 \cdot n_{xy}}{\sqrt{(n_x - n_y)^2 + 4 \cdot n_{xy}^2} - (n_x - n_y)}. \quad (4.22)$$

### 4.3 SLAB ELEMENTS

#### 4.3.1 Slab elements without conventional reinforcement

(1) For slab elements without conventional reinforcement with prevalent bending actions (Figure 4-3), the verification can be carried out in reference to the resistance moment,  $m_{Rd}$ , evaluated by considering a rigid plastic relationship (Figure 2-6):

$$m_{Rd} = \frac{f_{t,ud} \cdot t^2}{2} \quad (4.23)$$

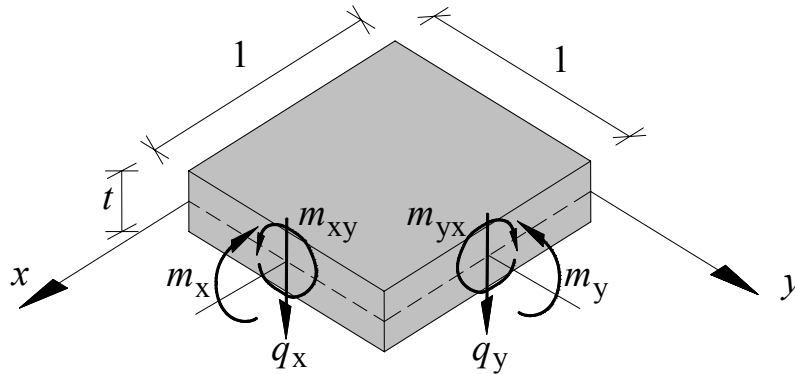

**Figure 4-3** – Slab element under flexure

(2) When a combined action of the two bending moments  $m_x$  e  $m_y$ , acting in orthogonal directions is present, the ULS verification requires the following relationship be satisfied:

$$\left( \frac{m_x}{m_{Rd}} \right)^2 + \left( \frac{m_y}{m_{Rd}} \right)^2 \leq 1. \quad (4.24)$$

(3) The statically undetermined structural effect, necessary when softening materials are used, can be taken into account if non linear analysis methods are adopted (e.g. limit analysis, incremental non linear analysis).

#### 4.3.2 Slab element with conventional reinforcement

(1) The verification of FRC elements with conventional reinforcement can be carried out with non linear analysis method (e.g. limit analysis, incremental non linear analysis).

## 5 SERVICEABILITY LIMIT STATES (SLS)

### 5.1 STRESS VERIFICATION

- (1) The compressive stresses at SLS shall be limited in accordance to the current Codes.
- (2) When structural elements with softening FRCs are considered, the verification of the tensile stresses is satisfied if the element is verified at ULS.
- (3) When structural elements with hardening FRCs are considered, the tensile stresses verification shall be done by imposing the limitation:

$$\sigma_i \leq 0.6 \cdot f_{Ftuk}. \quad (5.1)$$

### 5.2 CRACK WIDTH

- (1) The characteristic crack width  $w_k$ , in FRC elements can be evaluated by using the following relationship:

$$w_k = \beta \cdot s_{rm} \cdot \varepsilon_{sm}, \quad (5.2)$$

where:

- $s_{rm}$  is the average crack spacing, evaluated with equation (2.4);
  - $\varepsilon_{sm}$  is the mean strain in the reinforcement under the relevant combination of loads, including the effect of imposed deformations, taking into account the effects of tension stiffening (in accordance with the current Codes);
  - $\beta$  is a coefficient that correlates the average crack width with the value calculated according to the current Codes for the concrete matrix (without fiber reinforcement).
- (2) For the evaluation of  $\varepsilon_{sm}$ , FRC tensile strength can take into account and a constant stress distribution over the cross section equal to  $f_{Ftsk}$  can be rounded.

### 5.3 MINIMUM REINFORCEMENT FOR CRACK CONTROL

- (1) For cracking control in the elements under bending, a minimum reinforcement should be present, its area should be present and greater than:

$$A_{s,min} = (k_c \cdot k_s \cdot k_p \cdot f_{ctm} - f_{Ftsm}) \cdot \frac{A_{ct}}{\sigma_s}, \quad (5.3)$$

where:

- $f_{ctm}$  is the average value of the tensile strength of the concrete matrix;
- $f_{Ftsm}$  is the average value of the residual strength of the FRC;
- $A_{ct}$  is the tensile part of the concrete cross section, evaluated by considering a stress field at the elastic limit;

- $\sigma_s$  is the maximum tensile stress in the reinforcement after cracking, that can be considered equal to the yielding stress of the steel;
  - $k_c, k_s, k_p$  are correction coefficients in accordance to EC2.
- (2) When the value of  $A_{s,min}$  obtained by Eq. 4.27 is negative, the minimum reinforcement can be provided by fibers only.

## 6 CONSTRUCTION

The specific requirements for the construction of structural elements in fiber-reinforced concrete are reported in the following.

### 6.1 MIX COMPOSITION

- (1) The choice of the components and their dosage in the mix, can be made in accordance to both the mechanical properties required as well as the geometry of the structural element to be realised.
- (2) In particular, both the fiber length as well as the maximum aggregate size shall be correlated in order to assure a uniform and effective fiber distribution. To fulfil this aim, the maximum aggregate size shall not be longer than 0.5 times the fiber length.
- (3) In order to reduce a possible fiber agglomeration, a continuous grading shall be adopted for the aggregate.
- (4) In order to assure a complete and uniform distribution of the fibers, their length is correlated to the minimum dimensions (thickness) of the structural element.

### 6.2 DETAILING OF REINFORCEMENT

- (1) The assembling and placing of the traditional reinforcement shall be made in accordance to the current Code.
- (2) Particular care should be paid for reinforcements placed at right angles with the casting direction, that can obstruct the regular flow of the fresh concrete within the framework. This aspect should be considered in the design phase so that these obstacles are avoided, thus preventing an irregular distribution.

### 6.3 MINIMUM DIMENSIONS

Unless particular requirements are given, the minimum thicknesses of the structural element to be realised,  $t$ , and the spacing of bars,  $i$ , are defined as a function of the fiber length,  $l_f$ , of the maximum aggregate size,  $d_a$ , and of the steel reinforcement diameter,  $\phi$ , as specified in the following.

The minimum value of the concrete cover is related to that as set out in the current Code for reinforced concrete structures (without fibers).

#### 6.3.1 Minimum thickness of structural members

- (1) The minimum thickness of the structural element,  $t$ , should satisfy the following limitations:
  - 1 minimum local value:  $t \geq 2.0 \cdot d_a$ ;
  - 2 cross-section without reinforcement or with one layer of reinforcement:  $t \geq 2.4 \cdot d_a$ ;
  - 3 cross-sections with more reinforcement layers:  $t \geq 4.0 \cdot d_a$ .

#### 6.3.2 Minimum value of spacing of bars and concrete cover

- (1) The minimum values of the clear distance between rebars are reported in Table 6-1 as a

function of the reinforcement typology.

**Table 6-1** – Minimum values of the spacing of bars as a function of the reinforcement typology

Reinforcement typology	bars spacing
Stirrups and meshes	$\geq 1.6 \cdot d_a$
	$\geq 0.8 \cdot l_f$
bars	$\geq 1.0 \cdot d_a$
	$\geq 1.0 \cdot \phi$
	$\geq 0.8 \cdot l_f$
prestressing tendons	$\geq 1.2 \cdot d_a$
	$\geq 2.0 \cdot \phi$
	$\geq 1.0 \cdot l_f$

(2) The minimum concrete cover for the steel reinforcement of FRC elements can be assumed equal to 80% of the minimum cover as set out in the current Code for reinforced concrete structures (without fibers).

## 6.4 CASTING

(1) Reference to the current Code shall be made in relation to the requirements for the frameworks and their surface treatments, for the support systems as well as the foundations.

(2) FRCs shall be produced by following the same procedures for ordinary cementitious materials, with the only exception being fiber introduction.

(3) In order to assure mix uniformity, the fiber state (loose, packed, glued) shall be evaluated, according to the specific need, before their introduction to the matrix. In particular situations, the adoption of devices for fiber sieving may be needed (disentangle device).

(4) The fresh mix shall be cast in order to assure good compacting and homogeneity, as well as attain its nominal and structural design characteristics. In order to fulfil this aim, special attention shall be given to vibration and construction modalities to prevent fiber segregation that could compromise their uniform distribution.

(5) Particular care shall be given close to the reinforcement, to the fastenings, to the small volumes as well as the interfaces between the concrete cast at different times.



## 7 FIRE RESISTANCE

(1) For the evaluation of the resistance capacity of structural elements in fiber-reinforced concrete  $R$ , subjected to fire loading, both experimental as well as analytical methods can be adopted.

The approach proposed by the code UNI 9502 or by any other code which provides for the adoption of the previously mentioned methods for reinforced concrete structures can be used.

(2) For the application of the experimental method reference should be made to the selected code, without any additional requirements.

(3) For the application of the analytical model with explicit reference to fiber-reinforced concrete with steel fibers, the following steps shall be followed:

- analysis of the design stress at the ULS with the load combination in accordance to the reference code;
- computation of the temperature distribution in the critical section of the structure through a thermal analysis which adopts the typical parameters of the plain concrete, in accordance to the reference code for the required exposure time;
- analysis of the resistance capacity of the critical section by adopting, for the concrete reinforced with steel fibers, the coefficient of mechanical degradation in compression  $K_{Fc}(T)$ , and in tension  $K_{Ft}(T)$ , both of them depending on the temperature  $T$ , to be evaluated on experimental basis (in Figure 7-1 the qualitative pattern of  $K_{Ft}(T)$  is plotted with a dashed line while the pattern to be assumed on the safe side, when no direct experimental tests are carried out, is plotted with a continuous line);
- on the contrary, in case of highly statically un-determined structures, a global analysis rather than a non-section analysis, is best suited.

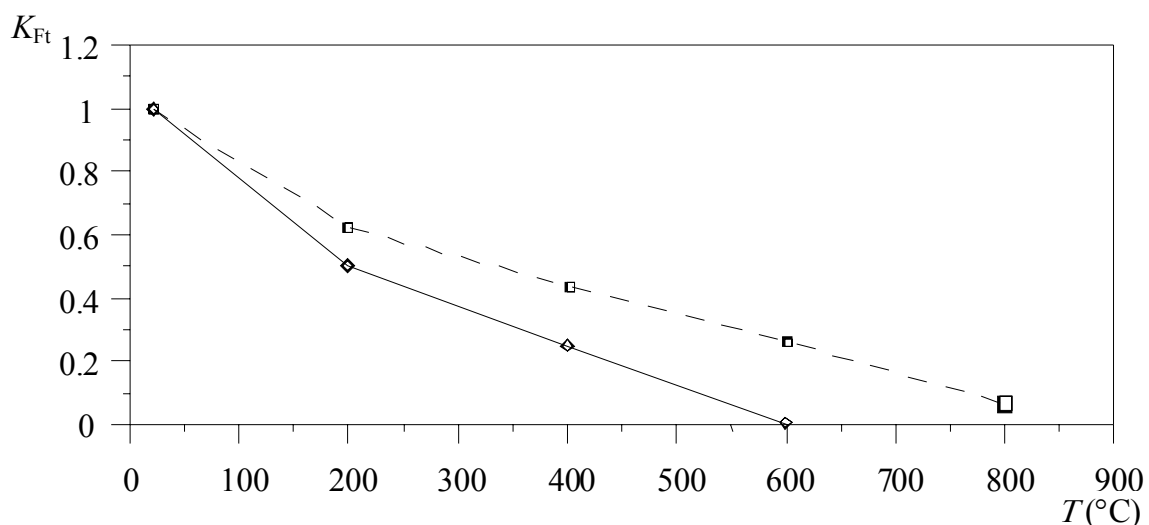

**Figure 7-1** – Coefficient of mechanical degradation  $K_{Ft}$ .

(4) For the evaluation of the contribution of the fiber-reinforced concrete to the bearing capacity, referring to the § 3.6.1, a partial coefficient  $\gamma_F$ , equal to 1.2 for type A applications and 1.1

for type B applications, is assumed.

(5) The degradation and safety coefficients of the other materials are assumed in accordance to the selected reference code.

(6) Instructions for the experimental evaluation of the degradation coefficient for steel fiber reinforced  $K_{Ft}(T)$  are reported in Appendix E, the behaviour in compression plain concrete can be assumed as a reference.

## 8 PRELIMINARY TESTS AND PRODUCTION CONTROL

### 8.1 PRELIMINARY TESTS

(1) For fiber reinforced structural elements, where fiber contribution takes part in the verification of the ultimate resistance, experiments have to be performed in order to confirm the design assumptions. These tests concern every type of element and, within the same type, the most loaded one, (where possible).

Preliminary tests should be carried out, otherwise final tests must be performed. In all cases, the applied loads must produce actions 20 % higher than those expected under serviceability conditions. Tests are considered positive if the experimental behaviour corresponds to the design assumptions.

### 8.2 PRODUCTION CONTROL FOR TYPE A APPLICATIONS

(1) Besides tests and controls foreseen in the reference standards for ordinary concrete structures, the production of fiber reinforced structural elements must be subjected to further specific controls, ensuring the conformity of products to functionality, durability and resistance requirements.

Other production controls, carried out under the surveillance of the responsible of the construction, are listed in Table 8-1:

**Table 8-1** – Tests performed during production.

Object	Properties	Method	Frequency	Recording
Fresh FRC	Correct mixing	visual inspection [see UNI EN 206-1 2001]	every day of casting of homogeneous mixture	proper form
Fresh FRC	Fiber content	*weight after the separation fiber-matrix [see CEN prEN 14721 2004]	every 50 m <sup>3</sup> of casting of homogeneous mixture or at least 2 controls a day	proper form
Hardened FRC	First cracking strength	Appendix A	Appendix B	proper form
Hardened FRC	Equivalent strength	Appendix A	Appendix B	proper form

(\*) only for steel fiber (other specifications have to be performed for different types of fiber )

(2) For manufactured elements, in which the homogeneous distribution of fibers is a particular feature, a control of the fiber content in the hardened concrete is foreseen.

For manufactured elements containing steel fibers, the control is carried out by means of microcoring and weighing after the separation of the fibers from the matrix, in accordance to CEN prEN 14721.

For manufactured elements, made of other fiber types, appropriate procedures have to be established.

### 8.3 PRODUCTION CONTROL FOR TYPE B APPLICATIONS

- (1) For type B applications (see § 3.6.1), apart from those specified in § 8.2, it is required that:
- the loading tests foreseen in § 8.1 must be preliminarily performed on, at least, 2 manufactured elements up to failure, in order to check the reliability of the design assumptions;
  - the production must be carried out in a quality system certified by an informed third party.

## 9 APPENDIX A (ON THE TENSILE STRENGTH: CONSTITUTIVE PARAMETER IDENTIFICATION)

### 9.1 SOFTENING BEHAVIOUR MATERIALS SUBJECTED TO TENSION IDENTIFIED THROUGH BENDING TESTS

#### 9.1.1 Linear elastic model

The linear elastic model identifies two reference values,  $f_{Fts}$  e  $f_{Ftu}$ , concerning SLS and ULS behaviour respectively.

They have to be defined through equivalent values of flexural strength, using the following equations:

$$f_{Fts} = 0.45 \cdot f_{eq1}, \quad (9.1)$$

$$f_{Ftu} = k \cdot \left[ f_{Fts} - \frac{w_u}{w_{i2}} \cdot (f_{Fts} - 0.5 \cdot f_{eq2} + 0.2 \cdot f_{eq1}) \right] \geq 0, \quad (9.2)$$

where:

- $f_{eq1}$  e  $f_{eq2}$  are, respectively, the post-cracking equivalent strength useful for the SLS and ULS (Figure 9-1a);
- $k$  is a coefficient equal to 0.7 for cross sections fully subjected to tensile stresses and equal to 1 in other cases;
- $w_{i2}$  is the mean value of the crack opening at the endpoints of the interval where  $f_{eq2}$  is evaluated in (Figure 9-1).

Equations (9.1) and (9.2) are still valid when, instead of the average values, the local values  $f_1$  and  $f_2$ , are considered, on condition that  $w_{i2}$  is assumed equal to the largest value of the considered interval (CTOD<sub>2</sub>; Figure 2-3).

These equations may be deduced through simple equilibrium considerations concerning rectangular section under bending, corresponding to the critical section of the tested specimen.

In particular, equation (9.1) may be deduced by assuming, for crack opening values, typical of serviceability conditions ( $w \leq 0.6$  mm), the following assumptions:

- plane sections;
- elasto-plastic tensile behaviour (with maximum value equal to  $f_{Fts}$ ; Figure 9-2a);
- linear-elastic compressive behaviour (Figure 9-2a).

Whether tension  $f_{Fts}$  and curvature  $\chi$ , corresponding to the critical section, are assumed as unknown, and the same modulus of elasticity is considered in tension and compression, the system (9.4) can be easily solved by assuming the following value of deformation at the lower chord:

$$\varepsilon_{F1} = \frac{w_{i1}}{l_{cs}}, \quad (9.3)$$

where:

- $w_{i1}$  is the mean value of the crack opening (CTOD<sub>0</sub> and CTOD<sub>1</sub>);
- $l_{cs}$  is the critical depth of the cross section, or the ligament depth  $h$  (Figure 9-3).

The corresponding system is the following:

$$N = 0,$$

$$M(\varepsilon_{F1}) = \frac{f_{eq1} \cdot b \cdot h^2}{6}. \tag{9.4}$$

In critical sections with depths ranging from 40 mm to 150 mm, the value of the constant that correlates  $f_{Fts}$  to  $f_{eq1}$  (9.1) changes but remains close to the suggested number 0.45.

The equation (9.2) is obtained considering a linear constitutive law between points with abscissa  $w_{i1}$  and  $w_{i2}$ , up to the point with abscissa  $w_u$  (Figure 9-2b).

The stress value corresponding to the crack opening  $w_{i2}$  is determined based on equilibrium (equation (9.5)), with the assumption that the compressive stress resultant is applied on the extrados chord (Figure 9-2b) and that the tensile behaviour is rigid-linear:

$$M(\varepsilon_{F2}) = \frac{f_{eq2} \cdot b \cdot h^2}{6}. \tag{9.5}$$

The value of  $\varepsilon_{F2} = w_{i2}/l_{cs}$  relates to the mean value of the crack opening interval, used to define  $f_{eq2}$ .

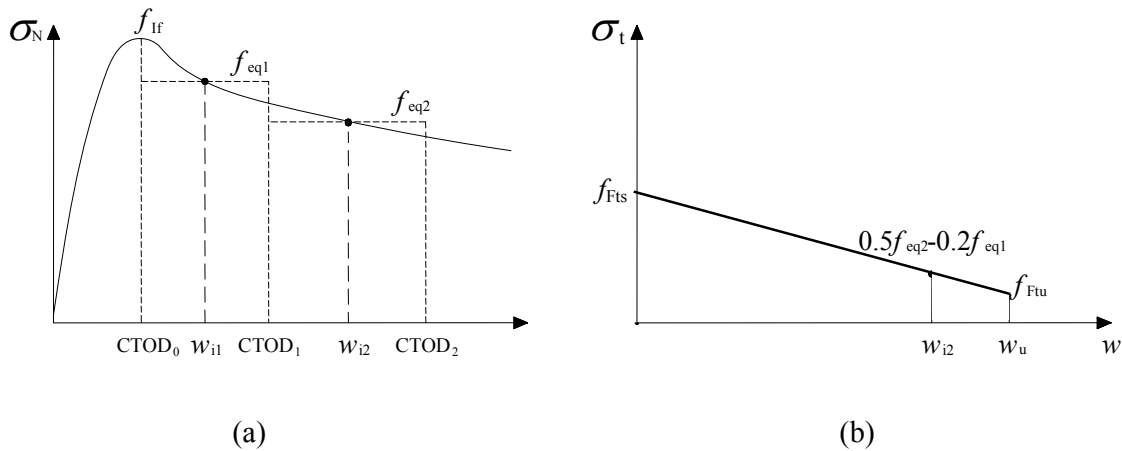

**Figure 9-1** – Tensile strength determined through bending test on softening materials.

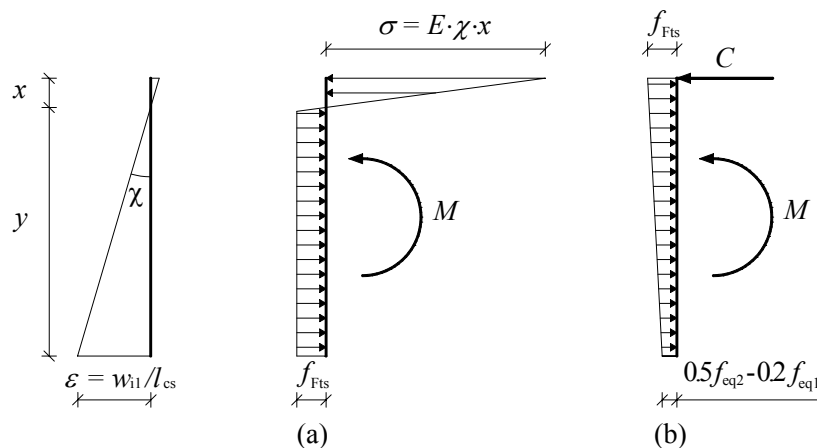

**Figure 9-2** – Stress diagrams for the determination of the tensile strength.

### 9.1.2 Rigid-plastic model

Rigid-plastic model identifies a unique reference value,  $f_{Ftu}$ , based on the ultimate behaviour. Such a value is determined as:

$$f_{Ftu} = \frac{f_{eq2}}{3}. \quad (9.6)$$

Equation (9.6) is obtained, from the equilibrium as in the previous case (with reference to ULS), but a constant tensile stress along the section is taken into account:

$$M_u = \frac{f_{eq2} \cdot b \cdot h^2}{6} = \frac{f_{Ftu} \cdot b \cdot h^2}{2}. \quad (9.7)$$

### 9.1.3 Notched specimen (according to UNI 11188)

With reference to a four point bending test, in accordance to the standard UNI 11039, the characteristic values of the equivalent strengths,  $f_{eq1k}$  and  $f_{eq2k}$ , are evaluated in the intervals  $0 \leq w \leq 0.6$  mm and  $0.6 \leq w \leq 3.0$  mm. Thus, by using the symbology of the standard UNI 11039, it is assumed:

$$f_{eq1k} = f_{eq(0-0.6)k}, \quad (9.8)$$

$$f_{eq2k} = f_{eq(0.6-3.0)k}. \quad (9.9)$$

These equivalent strengths correspond, respectively, to crack opening  $w_{i1}$  equal to 0.3 mm and  $w_{i2}$  equal to 1.8 mm, equivalent to the mean values of the selected intervals.

In order to consider the notch (Figure 9-3), the value of the tensile strength  $f_{Ft}$  (Figure 2-5) may be assumed equal to 0.9 times the value of the first cracking, deduced from the experimental test.

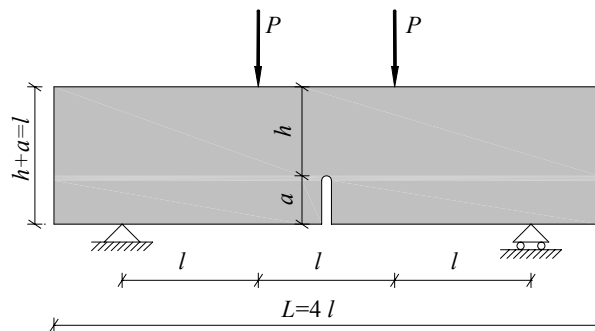

Figure 9-3 – Four point bending test on notched specimen.

### 9.1.4 Unnotched structural specimen (according to standard UNI 11188)

For structures subjected to bending, having a section depth less than 150 mm, or for hardening bending behaviour, it is better to carry out the identification process of material properties by taking into account the casting direction and the small thickness of the structure without notching the specimens. In this case, the characteristic values of the equivalent strengths,  $f_{eq1k}$  and  $f_{eq2k}$ , are evaluated in the intervals  $3 \cdot w_1 \leq w \leq 5 \cdot w_1$  and  $0.8 \cdot w_u \leq w \leq 1.2 \cdot w_u$ , where  $w_1$  represents the crack opening corresponding to cracking, calculated where the maximum load is recorded during the test,

in the interval  $0 \leq w \leq 0.1$  mm. For the ultimate crack opening,  $w_u$ , a value equal to 3 mm is assumed. By using the symbology of the standard UNI 11188, it is assumed:

$$f_{eq1k} = f_{1tFk} \quad (9.10)$$

$$f_{eq2k} = f_{Ftk} \quad (9.11)$$

These equivalent strengths correspond, respectively, to crack opening equal to  $w_{i1}=4 \cdot w_1$  and  $w_{i2}=w_u$ .

The value of the tensile strength,  $f_{Ft}$  (Figure 2-5), may be calculated based on the first cracking one,  $f_{ctf}$ , deduced from the experimental test:

$$f_{Ft} = \frac{f_{ct,exp}}{\beta(h)} \quad (9.12)$$

$$\beta(h) = \frac{25 + 2 \cdot h^{0.7}}{2 \cdot h^{0.7}} \quad [\text{mm}] \quad (9.13)$$

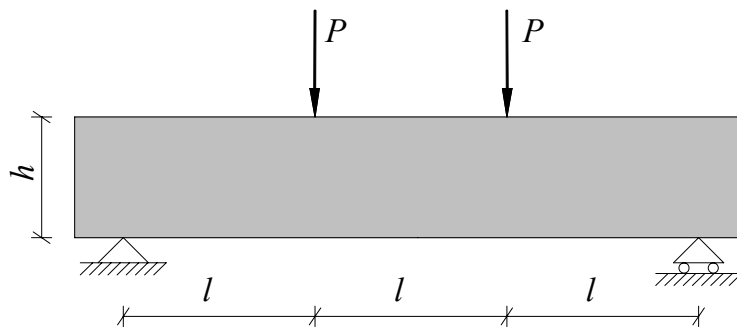

Figure 9-4 – Four point bending on unnotched specimen.

## 9.2 MATERIALS IDENTIFIED WITH TENSION TESTS

The constitutive parameters of both the linear-elastic and the rigid-plastic models (Figure 2-4), may be identified with uniaxial tension tests, with the nominal strengths being defined directly from the ratio between the selected load and the area of the specimen cross section.

Two reference values for the linear model,  $f_{Fts}$  ed  $f_{Ftu}$ , may be defined on the basis of the equivalent values:

$$f_{Fts} = f_{eq1} \quad (9.14)$$

$$f_{Ftu} = f_{Fts} - \frac{w_u}{w_{i2}} \cdot (f_{eq1} - f_{eq2}) \quad (9.15)$$

### 9.2.1 Notched specimen (according to UNI 11039)

Softening behaviour materials may be characterized by performing a uniaxial tension test on a notched specimen in accordance to UNI 11188. The characteristic values of the equivalent strengths,  $f_{eq1k}$  e  $f_{eq2k}$ , are evaluated in the intervals  $3 \cdot w_1 \leq w \leq 5 \cdot w_1$  and  $0.8 \cdot w_u \leq w \leq 1.2 \cdot w_u$ . The value  $w_1$  represents the crack opening corresponding to the conventional cracking onset, assumed as

the maximum load recorded, in the interval  $0 \leq w \leq 0.05$  mm. For the ultimate crack opening,  $w_u$ , a value equal to 1.5 mm is assumed. Referring to UNI 11188 symbology, the equivalent strengths are:

$$f_{eq1k} = f_{1tk}, \quad (9.16)$$

$$f_{eq2k} = f_{Ftk}. \quad (9.17)$$

These equivalent strengths correspond, respectively, to crack opening equal to  $w_{i1}=4 \cdot w_1$  and  $w_{i2}=w_u$ , that are the mean values of the selected intervals.

The value of the tensile strength,  $f_{Ft}$  (Figure 2-5), may be calculated based on the first cracking one, deduced from the experimental test, that corresponds to the value of the crack opening,  $w_1$ .

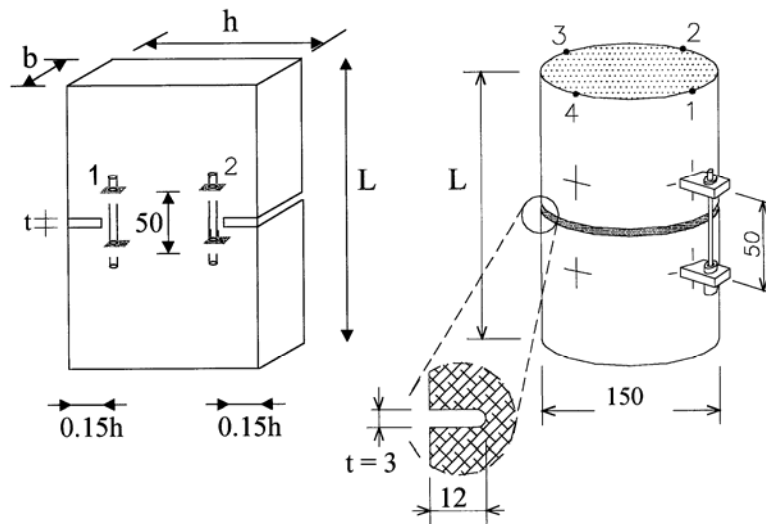

Figure 9-5 – Direct tension test on notched specimen (measure in mm)

### 9.2.2 Unnotched specimen

The characterization of materials with a hardening behaviour may be performed by means of uniaxial tension tests on an unnotched specimen as described in Appendix C.

In this case, the parameter  $w$  characterizes the relative displacement between two points located at an assigned distance (Appendix C).

The characteristic values of the equivalent strengths,  $f_{eq1k}$  and  $f_{eq2k}$ , are evaluated in the intervals  $3 \cdot w_1 \leq w \leq 5 \cdot w_1$  and  $0.8 \cdot w_u \leq w \leq 1.2 \cdot w_u$ . The value  $w_1$  represents the relative displacement corresponding to the cracking, calculated where the maximum load is recorded during the test, in the interval  $0 \leq w \leq 0.05$  mm. The ultimate value of  $w_u$  corresponds to a mean strain equal to 1% (Chapter 2, § 2.5.3.2) and, thus, it is equal to 0.01 times the gauge length.

The equivalent strengths,  $f_{eq1k}$  and  $f_{eq2k}$ , correspond to relative displacements equal to:  $w_{i1} = 4 \cdot w_1$  and  $w_{i2} = w_u$  respectively.



## 10 APPENDIX B (QUALITY CONTROL CRITERIA)

The production control is different for softening and hardening behaviour materials.

For softening materials, both bending tests on notched as well as unnotched specimens, and tension tests on notched specimens may be carried out. The production control on hardening materials must be performed through a uniaxial tension test on unnotched specimens. For hardening materials, in the case of continuative productions, it is possible to perform the production control by means of bending tests, as specified in Appendix C, after having calibrated the relation between these tests and the direct tension ones on unnotched specimens. The last ones must be periodically performed, at least every six months and in particular, whenever a significant modification of the production process occurs.

The sampling criteria of fiber reinforced concrete used for structural applications are reported in the current standards concerning the compressive strength of the ordinary concrete.

Similarly, the compressive strength is determined through the criteria reported in the current standards regarding ordinary concrete.

### 10.1 BENDING TESTS ON SOFTENING BEHAVIOUR MATERIALS

The production control on the material has to be carried out in accordance to the standards set out in UNI 11039 for notched specimens and UNI 11188 for unnotched structural specimens as well as other international standards.

Conformity with the characteristic values of the first cracking,  $f_{Ft}$ , and the equivalent bending strength,  $f_{eq1}$  and  $f_{eq2}$ , must be checked by choosing either type A or type B control (Table 10-1).

The relations between the parameters  $f_{Ft}$ ,  $f_{eq1}$ ,  $f_{eq2}$ , and those introduced in the various test arrangements are reported in Appendix A.

**Table 10-1** – Minimum possible values for the conformity control.

Production	Number $n$ of the test results	Criterion 1	Criterion 2
		Average of $n$ results $x_j$ $\bar{x}$ [MPa]	Every single test results $x_j$ [MPa]
Type A control	$\geq 3$	$\geq x_k + \Delta$	$\geq x_k - \Delta/2$
Type B control	6	$\geq x_k + 1.87 \cdot \sigma$	$\geq x_k - \Delta/2$
	7	$\geq x_k + 1.77 \cdot \sigma$	
	8	$\geq x_k + 1.72 \cdot \sigma$	
	9	$\geq x_k + 1.67 \cdot \sigma$	
	10	$\geq x_k + 1.62 \cdot \sigma$	
	11	$\geq x_k + 1.58 \cdot \sigma$	
	12	$\geq x_k + 1.55 \cdot \sigma$	
	13	$\geq x_k + 1.52 \cdot \sigma$	
	14	$\geq x_k + 1.50 \cdot \sigma$	
	15	$\geq x_k + 1.48 \cdot \sigma$	

In Table 10-1:

- $\sigma$  is the standard deviation;
- $\Delta$  is equal to 0.5 with reference to  $f_{Ft}$  and  $0.35 \bar{x}$  to  $f_{eq1}, f_{eq2}$ .

When assuming a multi-linear constitutive law or using other standards for the material characterization, the acceptance criteria are based on parameters related to equivalent bending strength, considered as reference data (as shown previously).

## **11 APPENDIX C (ON THE MECHANICAL CHARACTERIZATION TESTS FOR HARDENING BEHAVIOUR MATERIALS)**

### **11.1 TENSION TEST**

Structural parameters characterizing the tensile behaviour may be determined through a direct tension test on an unnotched specimen, as specified later or in accordance to international Standards.

The test aims to determine the tension-strain curve with particular reference to the tensile strength at cracking onset and to the ultimate strength as well as the corresponding strains, as specified in § 2.5.2.3.

#### **11.1.1 Specimen preparation**

The test specimen shall have sizes and geometry as reported in Figure 11-1 (total length: 330 mm). The thickness,  $t_p$ , of the specimen must be 5 times larger than the maximum aggregate size and not smaller than 13 mm. The width,  $b_p$ , must be 5 times larger than the maximum aggregate size and not smaller than 30 mm.

The specimens may either be cut out from the structural element or contemporarily or separately cast according to the same modalities (including the orientation) applied to the structural element.

If the specimen is separately cast, it must be cured according to the same modalities used for the structural element.

#### **11.1.2 Test equipment**

The testing machine must comply with the standard CEN-EN-12390-4 regarding the following points:

- force measure;
- accuracy of the force indication;
- frequency of calibration;
- safety.

The test machine must be provided with a proper device which allows the tests to be carried out under displacement control.

The test specimen is secured by means of appropriate clamps positioned at the enlarged ends, using a particular device in order to spread the local stresses. Clamps must be completely free to rotate in any direction.

The load must be measured by means of a load measurement system with a relative error less than  $\pm 1\%$ , a repeatability error less than 1%, a zero relative error (% of full scale) less than  $\pm 0.2\%$ , a machine resolution less than 0.5%.

The testing equipment measures the relative displacement between two points, 80 mm spaced, placed, at least, in two opposite specimen sides, as shown in Figure 11-2.

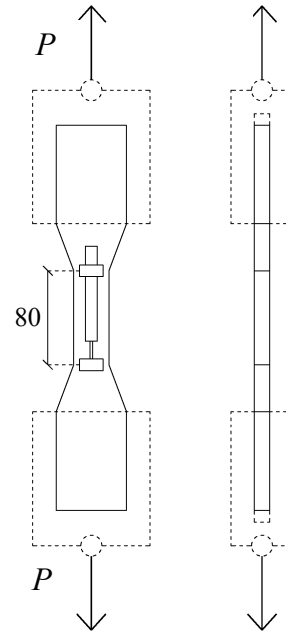
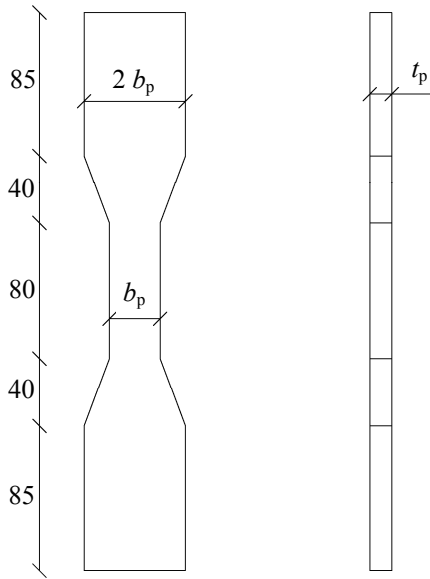

**Figure 11-1** – Specimen geometry [mm]. **Figure 11-2** – Direct tension test arrangement [mm].

### 11.1.3 Load application

The tension test must be carried out by either controlling the stroke displacement or the relative displacements of the reference points. The control parameter must be constantly increased at a speed of  $0.05 \pm 0.01$  mm/min. The load and the displacement values have to be continuously recorded on magnetic supports. The test must be continued until the value of the relative mean displacement is not less than 0.8 mm.

The nominal stress-strain curve is determined by dividing the load by the nominal area of the cross section and the relative displacement by the gauge length, equal to 80 mm.

## 11.2 BENDING TEST

The bending test may be carried out only for production control, instead of the tension test, after performing the latter test and the relative determination of the correlation parameters.

The structural parameters, (i.e. the bending strength), may be determined performing a four point bending test on either unnotched or notched specimens, as indicated for softening behaviour materials.

## 12 APPENDIX D (MATERIAL STRENGTH: CALCULATION OF CHARACTERISTIC VALUES FOR STRUCTURAL DESIGN)

In statically undetermined structures, wide cracked regions and significant redistributions occur at failure. Consequently, the characteristic values obtained from small size specimens do not represent the lowest ones.

As a result, the effect of the structural redundancy on the topological inhomogeneities of fiber reinforced concrete may be experimentally evaluated by means of qualification tests, carried out on proper structures reproducing the real ones.

Without suitable experimental tests, the strength increase may be taken into account by using (equation (3.7)):

$$f_{Ftk} = f_{Ftm} - \alpha \cdot k \cdot s, \quad (12.1)$$

where:

$$0.5 \leq \alpha = \left[ 1 - 0.1 \cdot \left( \frac{\nu}{2 \cdot \nu_0} - 1 \right) \cdot \left( \frac{\alpha_u}{\alpha_1} - 1 \right) \right] \leq 1.0. \quad (12.2)$$

The  $k$  value defined in (12.1) is assumed equal to 1.48. Furthermore, without specific experimental-theoretical analysis, values of  $\nu$ , numerator of the ratio  $\nu/\nu_0$  (ratio between the element volume and the reference volume), and the ratio  $\alpha_u/\alpha_1$  (ratio between the maximum load and that corresponding to the elastic limit) are given in Table 12-1.

**Table 12-1** – Values of  $\nu$  and  $\alpha_u/\alpha_1$  for different structural applications.

Structural application	Example of element and cracking	$\frac{\alpha_u}{\alpha_1}$	$\nu$
Statically determined beam with minimum longitudinal reinforcement subjected to bending		1.2	$l_{cs} \cdot a \cdot h$
Statically undetermined beam with longitudinal reinforcement subjected to bending		1.4 *	$(l_{cs1} + l_{cs2}) \cdot a \cdot h$
Beam with conventional shear reinforcement larger than the minimum one according to EC2		1.2	$l_{cs} = l_{cs}(\rho_{st})$ $l_{cs}^{**} \cdot t \cdot l_f^{***}$

%

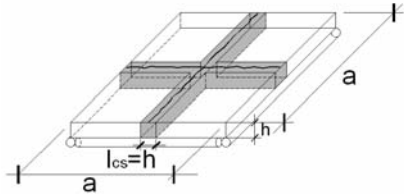
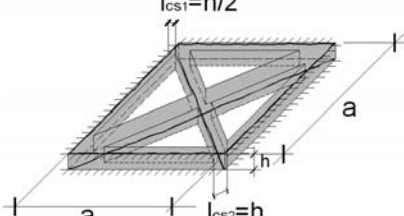
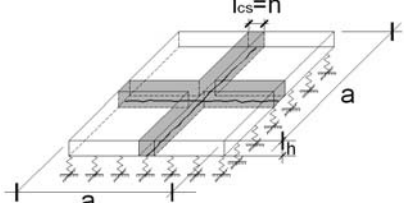
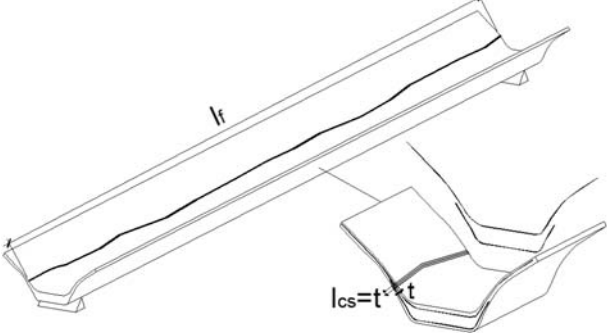
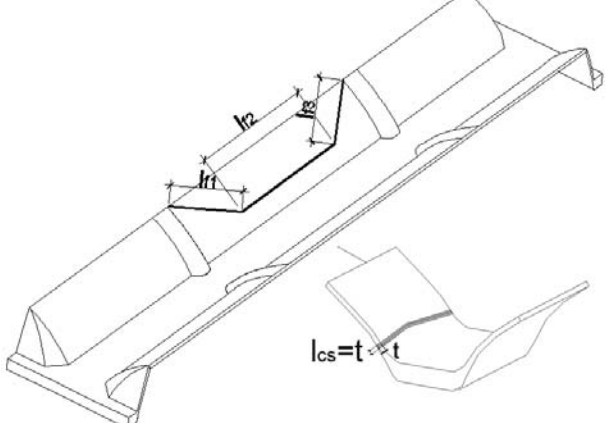
Simply supported slab subjected to bending		1.3	$2 \cdot l_{cs} \cdot a \cdot h$
Clamped slab subjected to bending		2	$(2 \cdot l_{cs1} + \sqrt{2} \cdot l_{cs2}) \cdot 2 \cdot a \cdot h$
Ground floor slab		3	$2 \cdot l_{cs} \cdot a \cdot h$
Thin webbed open cross section element with minimum shear reinforcement subjected to transversal bending		1.2	$l_{cs} \cdot t \cdot l_f^{***}$
Thin webbed open cross section element with minimum shear reinforcement subjected to transversal bending		1.2	$l_f^{***} = l_{f1} + l_{f2} + l_{f3}$ $l_{cs} \cdot t \cdot l_f^{***}$

\* for statically undetermined beam larger values may be used only if resulting from specific experimental tests.

\*\*  $l_{cs} = l_{cs}(\rho_{st})$ , where  $\rho_{st}$  is the geometrical reinforcement ratio in the transversal direction.

\*\*\*  $l_f$  crack length.

The reference volume,  $v_0$ , is defined as the volume involved in the cracking process of the tested specimen. With reference to a UNI 11039 specimen, whose dimensions are  $150 \times 150 \times 110 \text{ mm}^3$ , it results  $v_0 = 3.375 \text{ dm}^3$  (Figure 12-1).

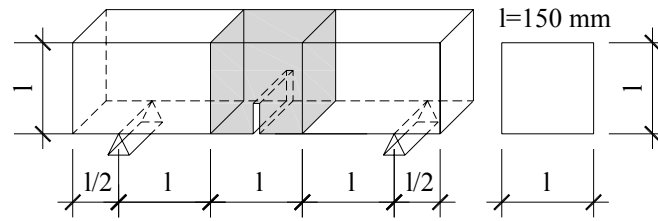

**Figure 12-1** – Reference volume in the four point bending specimen adopted by UNI 11039 and EN 14651.

## 13 APPENDIX E (EXPERIMENTAL DETERMINATION OF DAMAGE COEFFICIENTS DUE TO FIRE)

The experimental determination of the damage coefficients of steel fiber reinforced concrete,  $K_{Fc}(T)$  e  $K_{Ft}(T)$ , may be performed through compression and direct tension tests on specimens previously subjected to cyclic heating, without considering the effects of the instantaneous temperature on the material mechanical behaviour.

Cyclic heating must be carried out in an oven reaching maximum temperatures of 200, 400, 600 and 800 °C. The material must be heated at a speed of 30 °C/h, until the maximum reference cycle temperature is achieved. The temperature must be kept constant and equal to the maximum cycle temperature for at least 2 hrs. After that, the specimen has to be cooled at a speed of 12 °C/h, until room temperature is reached.

### *Compression test*

The damage coefficient  $K_{Fc}(T)$  for compressive strength is determined after a heating cycle, by calculating the ratio between the final compressive strength of the thermally damaged material, evaluated according to the same criteria reported in the current standards adopted for ordinary concrete, and the corresponding strength of the same material that is not subjected to any thermal treatment.

### *Direct tension test*

The damage coefficient  $K_{Ft}(T)$  for direct tensile strength, is determined from the ratio between the tensile strength of the thermally damaged material and the corresponding strength of the same material that is not subjected to any thermal treatment. It has to be computed with reference to the values  $f_{Fts}$  and  $f_{Ftu}$ , characterizing the post-cracking linear model, as mentioned in Appendix A.

### *Softening material*

When the material has a softening behaviour at room temperature, the direct tension test must be carried out on specimens subjected to cyclic heating. Specimens shall be notched after thermal cycle. The test and the specimen preparation after the cyclic heating must be performed in accordance to the modalities described in the standard UNI 1188, relating to fiber reinforced concrete specimens not subjected to any thermal treatment.

### *Hardening material*

When the material has a hardening behaviour at room temperature, the direct tension test must be carried out on unnotched specimens subjected to cyclic heating. The test and the specimen preparation must be performed in accordance to the procedures described in Appendix C concerning thermally undamaged specimens made of hardening material.

In order to evaluate the effects of the instantaneous temperature on the material mechanical properties, after one thermal cycle, a set of comparative bending tests may be performed. For every reference temperature (200, 400, 600 ed 800 °C), tests at room temperature on specimens previously subjected to a thermal cycle and tests on specimens quickly extracted from the oven. must be carried out

With particular reference both tests, the generic prismatic specimen that, in accordance to UNI 1188, is unnotched, must be heated at a temperature rate of 30 °C/h until the reference temperature is reached and then kept at that temperature for at least 2 hrs. Under this condition, it may be



subsequently subjected to a bending test, using precautionary measures to limit the quick cooling of the specimen.

The test procedure requires that the specimen is not equipped with testing instruments and the load is applied imposing a displacement rate equal to 1mm/min for values of the tensile stresses less than the maximum one, or equal to 2 mm/min in the other cases.